

PARTS LIST				
KEY	PART No.	DESCRIPTION	MATERIAL	QTY.
1	300-31-1F	BODY	D.I., A536 Gr. 65-45-12	1
2	300-31-2	BONNET	D.I., A536 Gr. 65-45-12	1
3	300-3-4-SCW	STEM	AISI 304 SS	1
4	300-4-5	BONNET CAP	D.I., A536 Gr. 65-45-12	1
5	300-4-6-SCW	WEDGE	AL BRZ, B148-954	1
6	300-3-8	DISC	AL BRZ, B148-954	2
7	300-3-9	SEAT	AL BRZ, B505-C95400	2
8	300-4-10-SCW	WRENCH NUT	D.I., A536 Gr. 65-45-12	1
9	300-3-11	BONNET GASKET	GARLOCK STYLE 19	1
10	HHCS.5-13X2.25	HHCS, 1/2-13 UNC x 2.25" LG	304 SS	6
11	FHN.5-13	STD HEX HD NUT, 1/2"-13 UNC	304 SS	7
12	HHCS.5-13X1.25	HHCS, 1/2-13 UNC x 1.25" LG	304 SS	4
13	PLG.375	PIPE PLUG, HEX HEAD, 3/8" NPTF	BRONZE	1
14	AS568A-227	O-RING SIZE -227	BUNA N DUROMETER 70	1
15	AS568A-212	O-RING SIZE -212	BUNA N DUROMETER 70	3

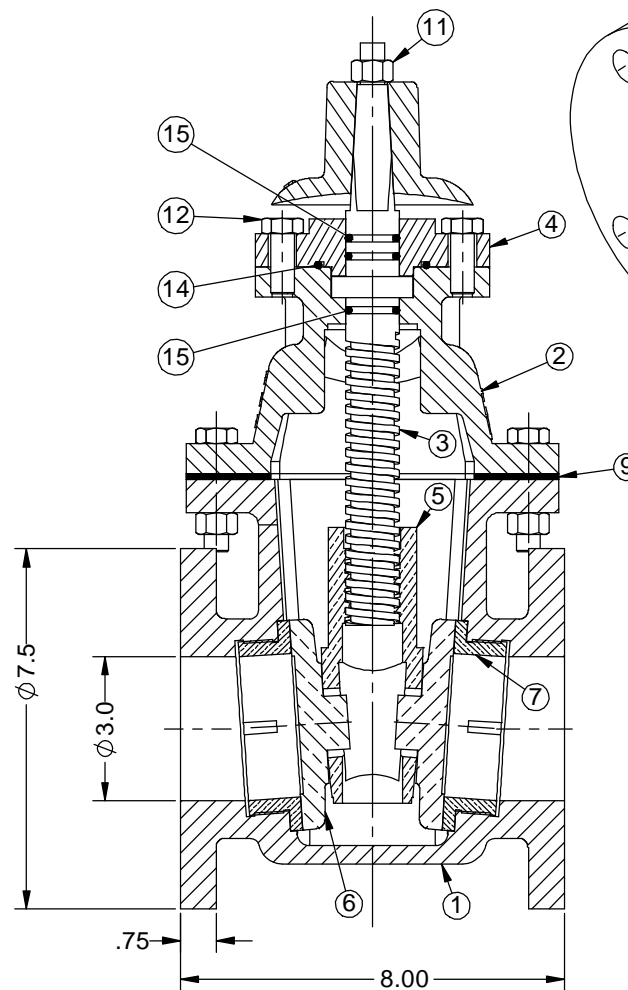

SECT C-C

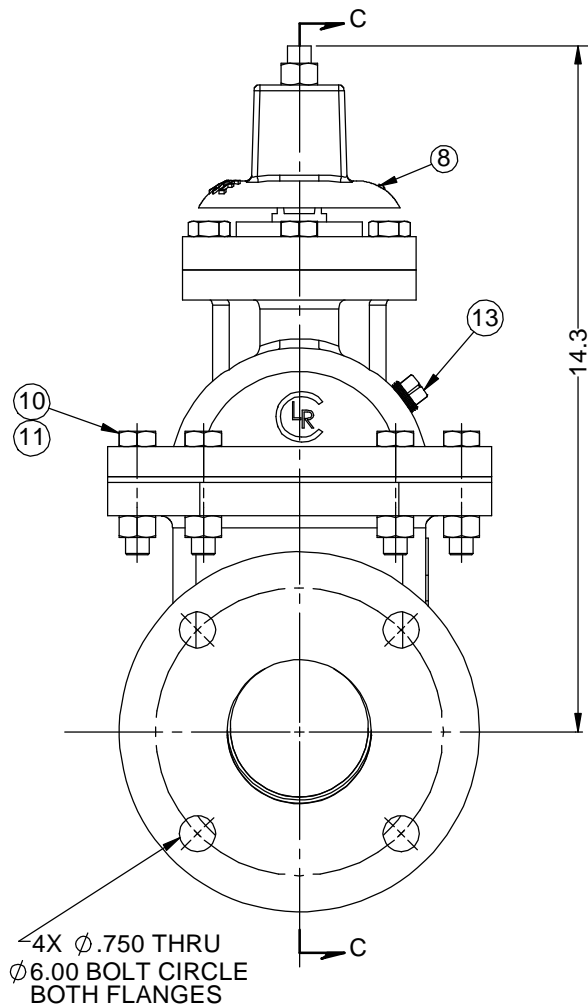
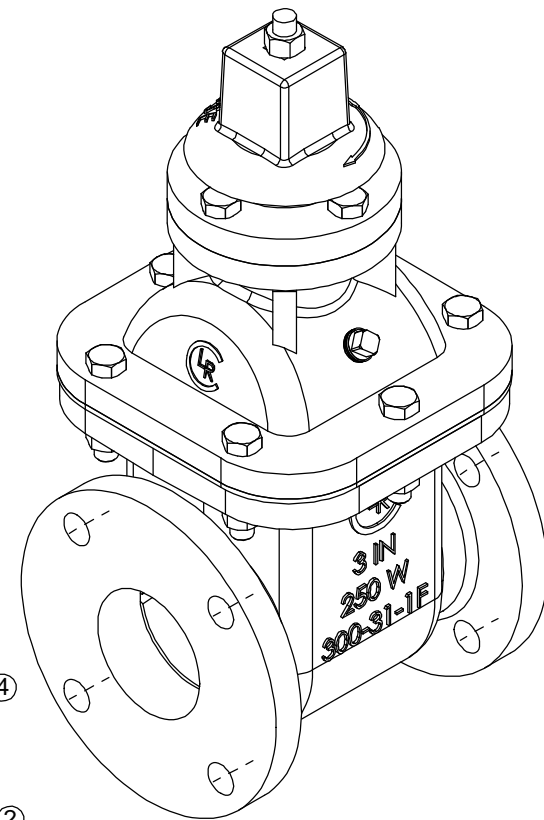

NOTES:

- 250 PSIG MAX. WORKING PRESSURE
- 500 PSIG HYDROSTATIC TEST PRESSURE
- ANSI B16.42 FLAT FACE FLANGED ENDS.
- APPROXIMATE WEIGHT: 73 LBS.
- VALVE WILL BE COATED INTERNALLY & EXTERNALLY WITH TNEMEC 141 EPOXY, 8-10 MILS DFT.
- MANUFACTURED IN ACCORDANCE WITH ANSI/AWWA C500, LATEST REVISION.
- P/N: LR0362123111129JOCF

REVISIONS			
REV	DESCRIPTION	DATE	APP'D

DRAWN			NAME			DATE			Ludlow-Rensselaer Gate Valves by Crispin Valves		
hWig			BBG			05/11/17			05/12/17		
DIMENSIONS ARE IN INCHES DO NOT SCALE DRAWING									3" CL. 150 FF, Series 300 Gate Valve, w/ 2" Sq. Nut, Close Clockwise		
FILE LOCATION: N:\GateValve\300\									SIZE C	DWG. NO. 9100750	REV 0
FILE NAME: 9100750									SCALE: 0.5:1	WT: 72 LB	SHEET 1 OF 1