

PARTS LIST				
KEY	PART No.	DESCRIPTION	MATERIAL	QTY.
1	300-121-1MJ	BODY	D.I., A536 Gr. 65-45-12	1
2	300-121-2	BONNET	D.I., A566 Gr. 65-45-12	1
3	300-12-4-SCW	STEM	AISI 304 SS	1
4	300-12-5	BONNET CAP	D.I., A536 Gr. 65-45-12	1
5	300-12-6-SCW	WEDGE, CLOSE CLOCKWISE	AL BRZ, B148-954	1
6	300-12-8	DISC	AL BRZ, B148-954	2
7	300-12-9	SEAT	AL BRZ, B505-C95400	2
8	300-12-10-SCW	WRENCH NUT	A536 Gr. 65-45-12	1
9	300-12-11	BONNET GASKET	GARLOCK STYLE 19	1
10	HHCS.625-11X3	HHCS, 5/8-11 UNC x 3.0" LG.	304 SS	18
11	FHN.625-11	STD HEX HD NUT, 5/8"-11 UNC	304 SS	19
12	HHCS.5-13X1.5	HHCS, 1/2-13 UNC x 1.5" LG	304 SS	4
13	PLG.375	PLUG, HEX HEAD, 3/8" NPTF	CARBON STEEL	1
14	AS568A-234	O-RING SIZE -234	BUNA N DUROMETER 70	1
15	AS568A-218	O-RING SIZE -218	BUNA N DUROMETER 70	3

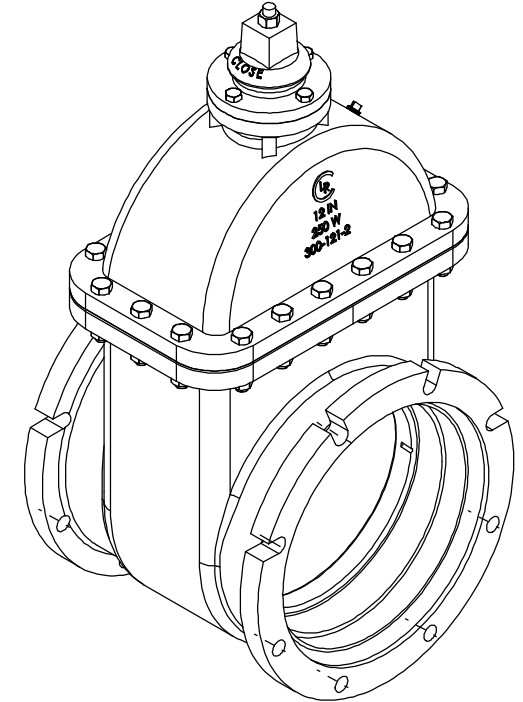
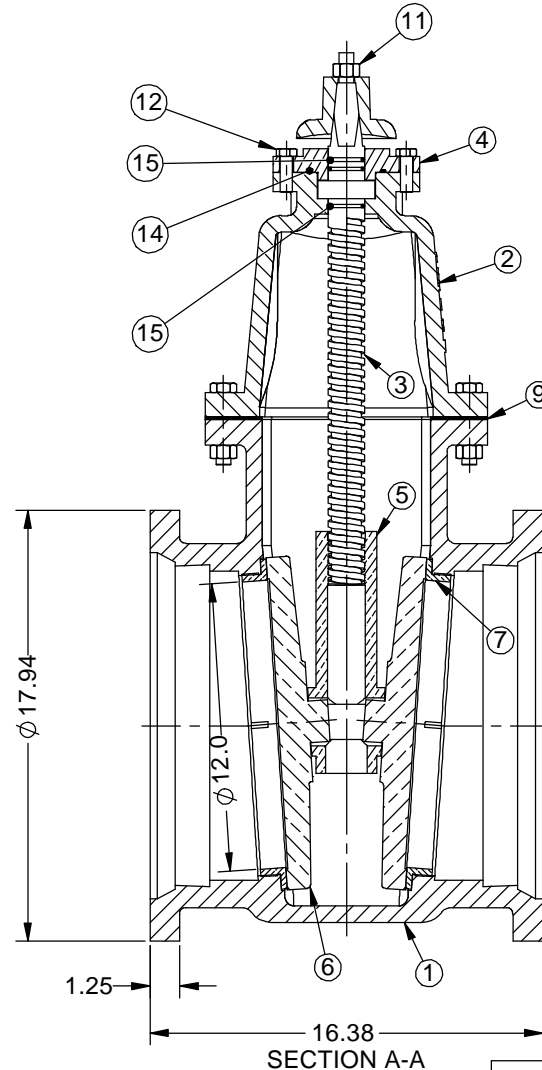
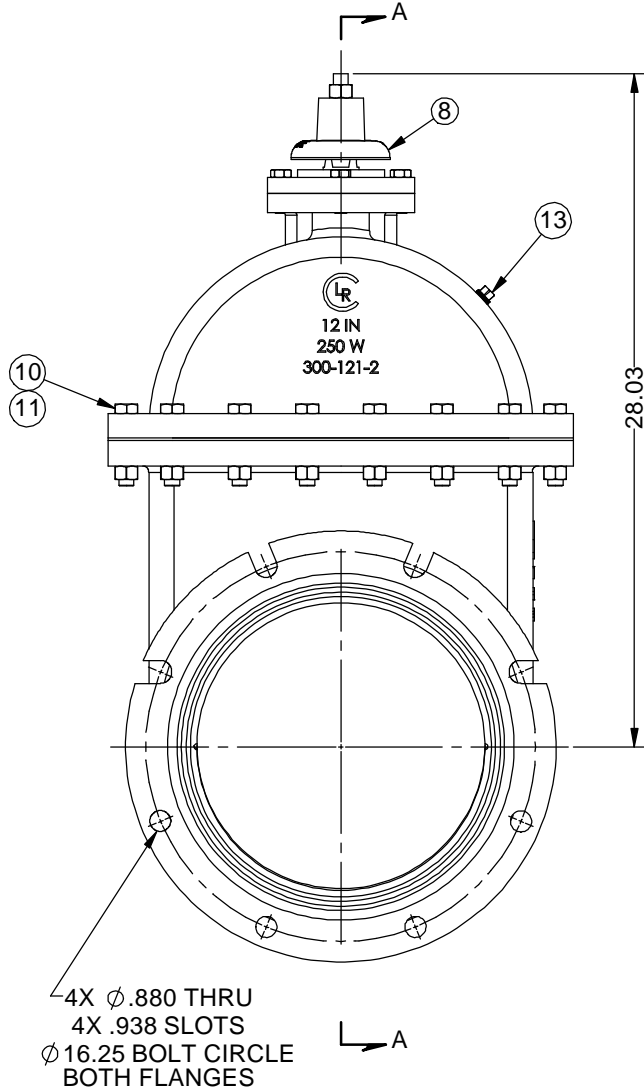

**NOTES:**

- 250 PSIG MAX. WORKING PRESSURE
- 500 PSIG HYDROSTATIC TEST PRESSURE
- MECHANICAL JOINT ENDS IN ACCORDANCE WITH ANSI/AWWA C111.
- APPROXIMATE WEIGHT: 512 LBS.
- VALVE WILL BE COATED INTERNALLY & EXTERNALLY WITH TNEC 141 EPOXY, 8-10 MILS DFT.
- MANUFACTURED IN ACCORDANCE WITH ANSI/AWWA C500, LATEST REVISION.
- Assy. P/N: LR1261123111129J0CF

REVISIONS			
REV	DESCRIPTION	DATE	APP'D

DRAWN	NAME	DATE	<b>Ludlow-Rensselaer Gate Valves by Crispin Valves</b>	
CHECKED	hWg	05/15/17	12" CL. 125 MJ, Fig. 306 Gate Valve, w/ 2" AWWA Sq. Nut, Close Clockwise	
DIMENSIONS ARE IN INCHES DO NOT SCALE DRAWING			SIZE <b>C</b>	REV <b>0</b>
FILE LOCATION: N:\GateValve\300\			DWG. NO. 9100761	SCALE: 0.25:1
FILE NAME: 9100761			WT: 510 LB	SHEET 1 OF 1