

KEY	PART No.	DESCRIPTION	MATERIAL	QTY.
1	300-101-1F	BODY	D.I., A536 Gr. 65-45-12	1
2	300-101-2	BONNET	D.I., A536 Gr. 65-45-12	1
3	300-10-4-SCW	STEM	AISI 304 SS	1
4	300-12-5	BONNET CAP	D.I., A536 Gr. 65-45-12	1
5	300-10-6-SCW	WEDGE	AL BRZ, B148-954	1
6	300-10-8	DISC	AL BRZ, B148-954	2
7	300-10-9	SEAT	AL BRZ, B505-C95400	2
8	300-10-11	BONNET GASKET	GARLOCK STYLE 19 CLOTH INSERTED RUBBER	1
9	300-10-12	HAND WHEEL	DUCTILE IRON	1
10	HHCS.625-11X3	HHCS, 5/8-11 UNC x 3.0" LG.	304 SS	18
11	FHN.625-11	STD HEX HD NUT, 5/8"-11 UNC	304 SS	19
12	HHCS.5-13X1.5	HHCS, 1/2-13 UNC x 1.5" LG	304 SS	4
13	PLG.375	PIPE PLUG, HEX HEAD, 3/8" NPTF	BRONZE	1
14	AS568A-234	O-RING SIZE -234	BUNA N DUROMETER 70	1
15	AS568A-218	O-RING SIZE -218	BUNA N DUROMETER 70	3

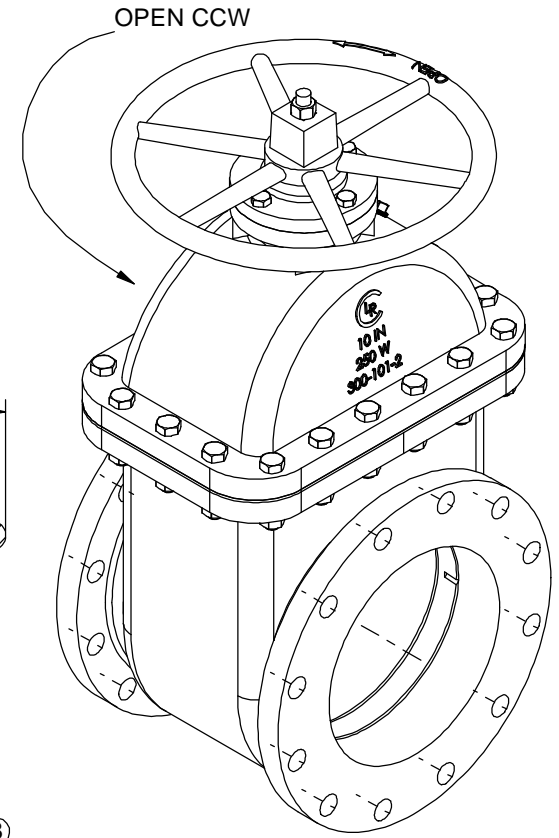
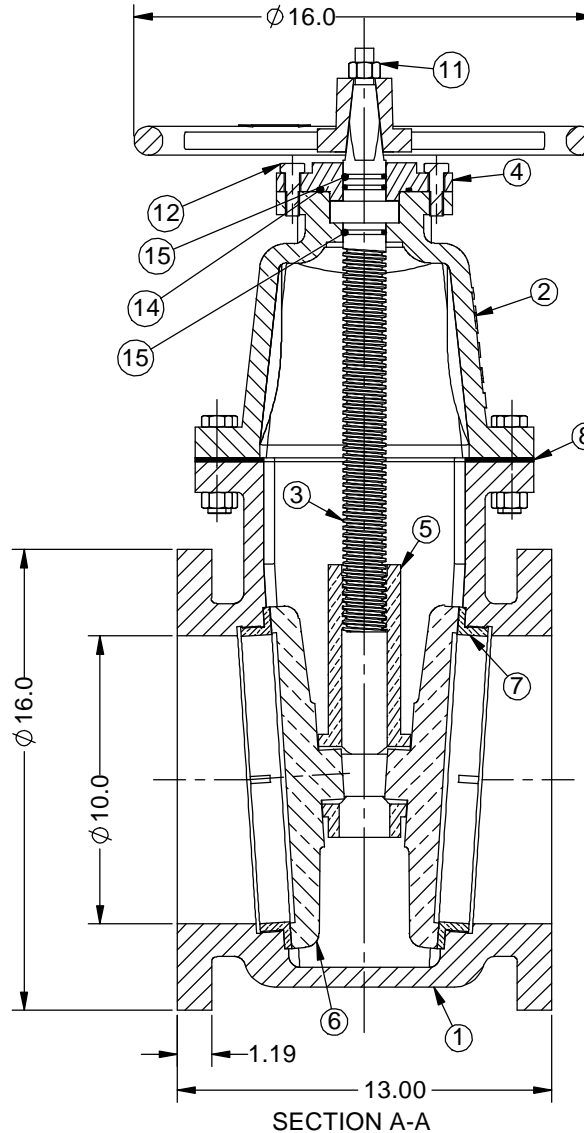
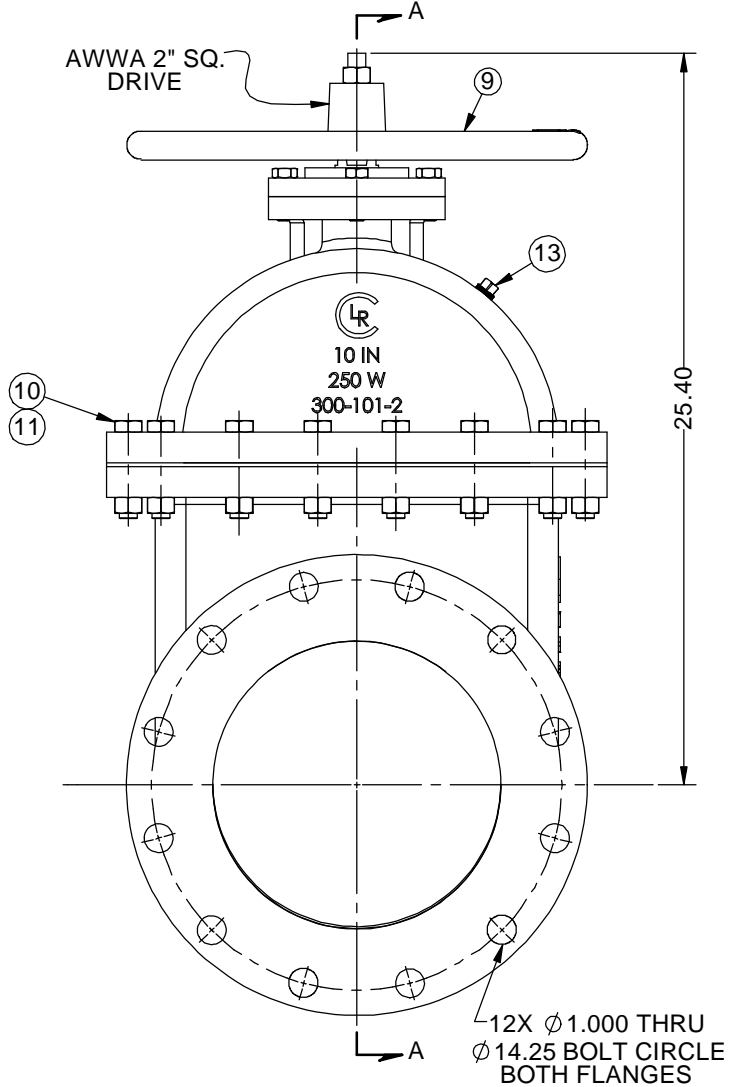

- NOTES:
- 250 PSIG MAX. WORKING PRESSURE
  - 500 PSIG HYDROSTATIC TEST PRESSURE
  - ANSI B16.42 FLAT FACE FLANGED ENDS.
  - APPROXIMATE WEIGHT: 425 LBS.
  - VALVE WILL BE COATED INTERNALLY & EXTERNALLY WITH TNEMEC 141 EPOXY, 8-10 MILS DFT.
  - MANUFACTURED IN ACCORDANCE WITH ANSI/AWWA C500, LATEST REVISION.

REV#	DESCRIPTION	DATE	APP'D

DRAWN	NAME	DATE	Ludlow-Rensselaer Gate Valves by Crispin Valves		
	hWig	06/05/19	10" CL. 150 FF, Series 300 Gate Valve, w/ Handwheel, Close Clockwise		
CHECKED	BBG	06/06/19	SIZE	DWG. NO.	REV
DIMENSIONS ARE IN INCHES DO NOT SCALE DRAWING			C	9101028	0
FILE LOCATION: N:\GateValves\300\			SCALE: 0.3:1	WT: 425 LB	SHEET 1 OF 1
FILE NAME: 9101028					