

Submittal Sheet for Crispin AR Series



SUBMITTAL SHEET FOR AR SERIES

1/2"–1" Pressure Air Release (AR)

Manufactured in compliance with ANSI/AWWA C512

Date: October, 2001

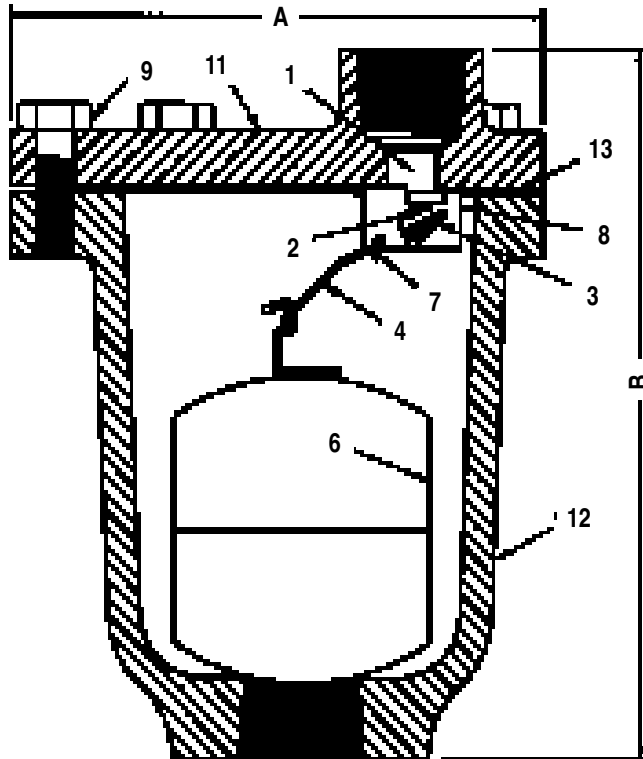

Parts List

ITEM	DESCRIPTION	MATERIAL	ASTM
1	SEAT	STAINLESS STEEL	A240
2	VALVE BUTTON	BUNA-N RUBBER	D2000
3	BUTTON CLIP	STAINLESS STEEL	A240
4	VALVE LEVER	STAINLESS STEEL	A240
6	FLOAT	STAINLESS STEEL	A240
7	PIN	STAINLESS STEEL	A193
8	HINGE BUTT	STAINLESS STEEL	A240
9	BOLT	STEEL	A307
11	FLANGE	CAST IRON	A126 CL.B
12	BODY	CAST IRON	A126 CL.B
13	GASKET	ARMSTRONG N-8092	N/A

Specifications

The valve(s) shall be installed at high points in the line to vent the accumulation of air and other gases with the line under pressure.

The valve(s) shall have a 5/64" orifice with valve sealing faces of stainless steel and Buna-N rubber. Valves which use a needle valve to seal the orifice shall not be acceptable.

The valve(s) shall be Crispin-Multiplex Model _____ Pressure Air Release Valve(s) as manufactured by Crispin-Multiplex Manufacturing Co., Berwick, PA.

Valve construction shall be _____" NPT screwed, cast iron body and top flange with stainless steel float and trim.

Size Specifications

MODEL	INLET SIZE	OUTLET SIZE	A	B	WEIGHT
AR5	1/2" NPT	1/2" NPT	4.25	5.50	5
AR8	3/4" NPT	1/2" NPT	4.25	5.50	5
AR10	1" NPT	1/2" NPT	4.25	5.50	5

Orifice

DIAMETER	MAX. PRESSURE	DISCHARGE RATE
5/64	150 PSIG	9.6 SCFM
5/64	300 PSIG	18.4 SCFM