

REVISIONS			
REV.	DESCRIPTION	DATE	APPROVED
1	PN ITEM 3 WAS 36-A2-8 PN ITEM 6 WAS F65-8 DESC. ITEM 6 WAS HHCS, 1/4-20 X .75 DESC. ITEM 12 WAS BLANK DESC. ITEM 14 WAS DOT MAT'L ITEM 3 WAS A276 TYPE 316 S.S.	03/22/07	

ITEM NO.	PART NUMBER	DESCRIPTION	MATERIAL	QTY.
1	52-2X	FLANGE	A276 TYPE 316 S.S.	1
2	36-A2-7	ROD GUIDE STAND	A240 TYPE 316 S.S.	1
3	36-A2S-8	FLOAT ROD GUIDE	NYLATRON	1
4	36-A2-11	ROD GUIDE NUT	A194 TYPE 316 S.S.	1
5	51-13	STAND ROD	TYPE 316 S.S.	3
6	36-A2-12	HHCS, 1/4-20 X .50	TYPE 316 S.S.	3
7	GASKET	GASKET	BUNA-N RUBBER	1
8	51-9A	FLOAT	TYPE 316 S.S.	1
9	TC FERRULE CLAMP	TC FERRULE CLAMP	TPYE 316 S.S.	1
10	27-3X	2" VALVE BODY	A351-CF8M TYPE 316 S.S.	1
11	3-5	SEAT	BUNA-N RUBBER	1
12	52-6	VALVE	A511 & A240/A276 TYPE 316 S.S.	1
13	3-1S	TOP	A276 TYPE 316 S.S.	1
14	X-DOT	DOT (RED)	6061 T6 ALUMINUM	1

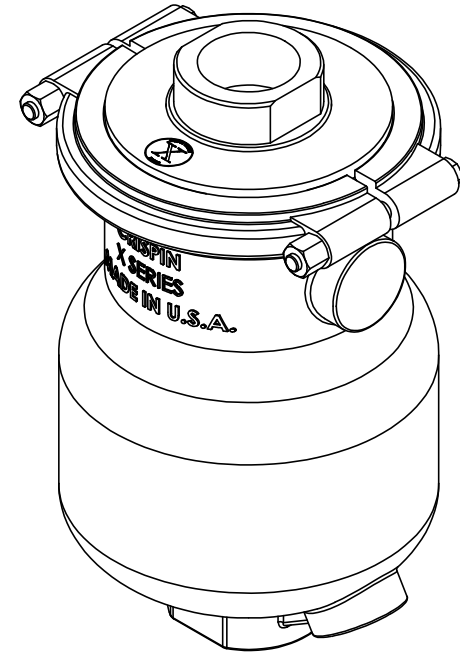
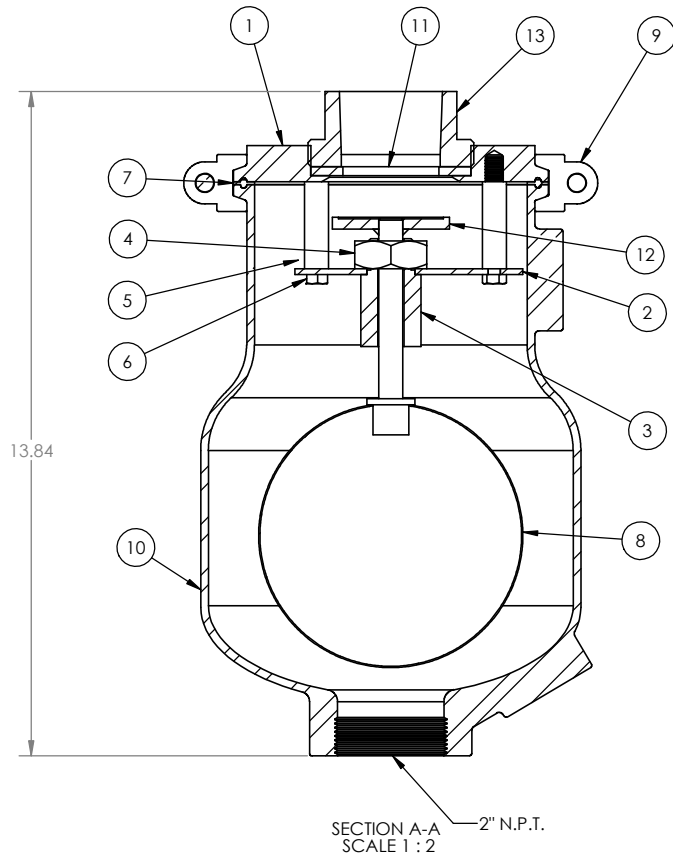

- NOTES:
1. INLETSIZE: 2"NPT; OUTLET SIZE: 2" NPT
  2. TESTED IN ACCORDANCE WITH LASTEST REVISION OF AWWA C512.
  3. 200 PSIG MAX. OPERATING PRESSURE.

SECTION A-A  
SCALE 1:2  
2" N.P.T.

PROPRIETARY AND CONFIDENTIAL  
THE INFORMATION CONTAINED IN THIS DRAWING IS THE SOLE PROPERTY OF CRISPIN VALVES. ANY REPRODUCTION IN PART OR AS A WHOLE WITHOUT THE WRITTEN PERMISSION OF CRISPIN VALVES IS PROHIBITED.

DIMENSIONS IN INCHES, UNLESS OTHERWISE SPECIFIED:

**MACHINES SURFACES:**  
DECIMAL: ±.010  
FRACTIONAL: UNDER 6 IN ± 1/64 (.016) 6 TO 18 IN ± 1/32 (.031) OVER 18 IN ± 1/16 (.063)  
ANGULAR: ± 2DEGREES

**UNMACHINED SURFACES:**  
DECIMAL OR FRACTIONAL: UNDER 6 IN ± 1/16 (.063) 6 TO 18 IN ± 1/8 (.125) OVER 18 IN ± 3/16 (.188)

COMMENTS:

MATERIAL	FINISH	NAME	DATE
		GDJ	8/31/2005
		CHECKED	
		ENG APPR.	



TITLE:  
2" X 2" "X SERIES"  
AIR & VACUUM VALVE

SIZE	DWG. NO.	REV
C	AX20-2	1

SCALE: 1:4 WEIGHT: 30.54 SHEET 1 OF 1