

PARTS LIST				
ITEM	PART NO	DESCRIPTION	MATERIAL	QTY
1	36-U3X-2	FLANGE	A351 Gr CF8M	1
2	28-3X	BODY	A351 Gr CF8M	1
3	AS568A-272	FLANGE O-RING	BUNA-N RUBBER	1
4	36-A3-6	VALVE ASSEMBLY	316 STAINLESS STEEL	1
5	36-A3X-5	SEAT	BUNA-N RUBBER	1
6	28-16X	FLOAT GUIDE STAND	A351 Gr CF8M	1
7	AC4-15	RETAINING BOLT	316 STAINLESS STEEL	6
8	36-A3-9	FLOAT	316 STAINLESS STEEL	1
9	28-11X	CLAMP HALF	A351 Gr CF8M	2
10	3-11FH	CLAMP BOLT	316 STAINLESS STEEL	2
11	LW.5	LOCK WASHER	316 STAINLESS STEEL	2
12	3-12	CLAMP NUT	316 STAINLESS STEEL	2
13	36-33	1" PLUG	316 STAINLESS STEEL	2

3" CLASS 150 INLET FLANGE DATA	
FLANGE DIAMETER	7.50 in.
FLANGE THICKNESS	0.94 in.
BOLT CIRCLE DIAMETER	6.00 in.
NUMBER OF BOLT HOLES	4
BOLT HOLE DIAMETER	0.75 in.

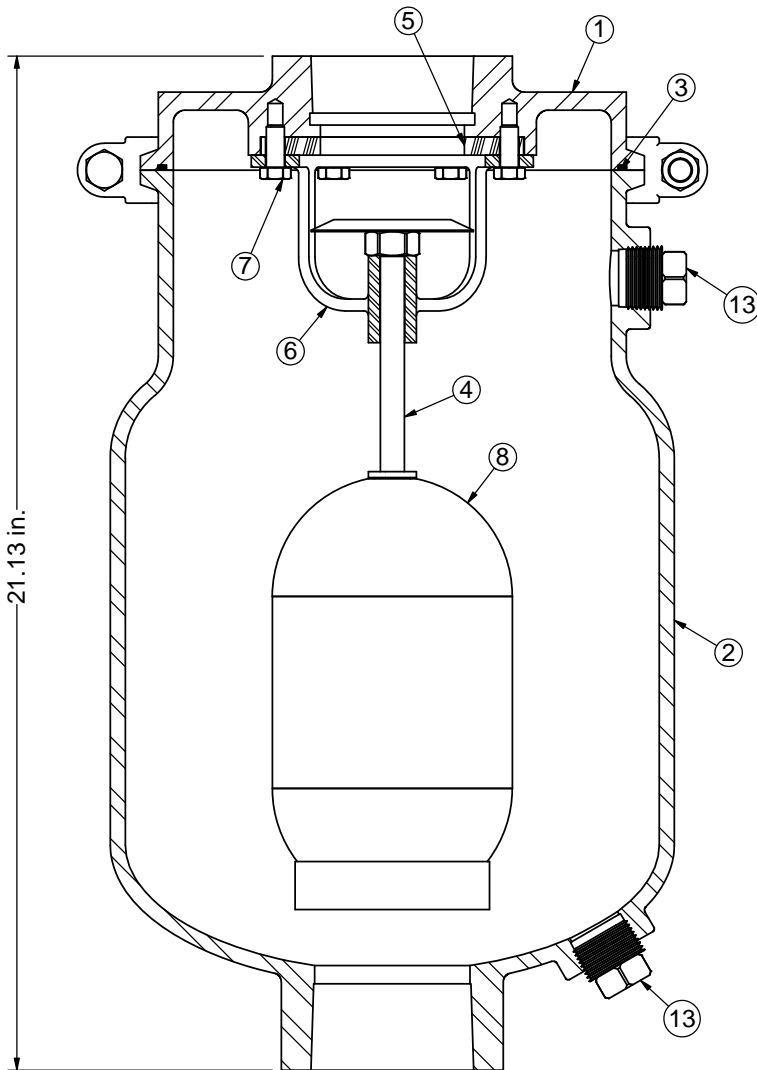

SECTION A-A

- NOTES:
 1. INLET SIZE: 3" NPT
 OUTLET SIZE: 3" NPT
 2. WORKING PRESSURE: 20-200 PSIG
 3. APPROXIMATE WEIGHT: 95 lbs

DO NOT SCALE DRAWING		Crispin Valves	
DIMENSIONS ARE IN INCHES UNLESS OTHERWISE SPECIFIED.		3" NPT, X SERIES, AIR & VACUUM VALVE	
FINISHED LINEAR TOLERANCES: ±0.015		SIZE	REV
UNFINISHED LINEAR TOLERANCE: +0.050 -0.020		C	1
FINISHED ANGULAR TOLERANCE: ±2°		DWG. NO.	AX30
1	CHANGED INTERNALS FOR CAST FLOAT GUIDE	DATE	10-21-15
REV	DESCRIPTION	APPROVED	BJL
REVISIONS		CHECKED	DATE
		BJL	7-22-16
		DRAWN	DATE
		DJF	7-22-16
		SCALE	0.5:1
		SHEET 1 OF 1	