

PARTS LIST				
ITEM	PART NO	DESCRIPTION	MATERIAL	QTY
1	36-U3X-2	FLANGE	316 STAINLESS STEEL	1
2	28-3XFF	BODY	A351 GR. CF8M	1
3	AS568A-272	FLANGE O-RING	BUNA-N RUBBER	1
4	36-A3X-5	SEAT	BUNA-N RUBBER	1
5	AC4-15	SEAT BOLT	316 STAINLESS STEEL	6
6	36-A3-6	VALVE ASSEMBLY	316 STAINLESS STEEL	1
7	36-A3-9	FLOAT	316 STAINLESS STEEL	1
8	28-16X	FLOAT GUIDE STAND	316 STAINLESS STEEL	1
9	28-11X	CLAMP HALF	A351 GR. CF8M	2
10	3-11FH	CLAMP BOLT	316 STAINLESS STEEL	2
11	LW.5	LOCK WASHER	316 STAINLESS STEEL	2
12	3-12	CLAMP NUT	18-8 STAINLESS STEEL	2
13	36-33	1" PLUG	316 STAINLESS STEEL	2

3" CLASS 150 INLET FLANGE DATA	
FLANGE DIAMETER	7.50 in.
FLANGE THICKNESS	0.94 in.
BOLT CIRCLE DIAMETER	6.00 in.
NUMBER OF BOLT HOLES	4
BOLT HOLE DIAMETER	0.75 in.

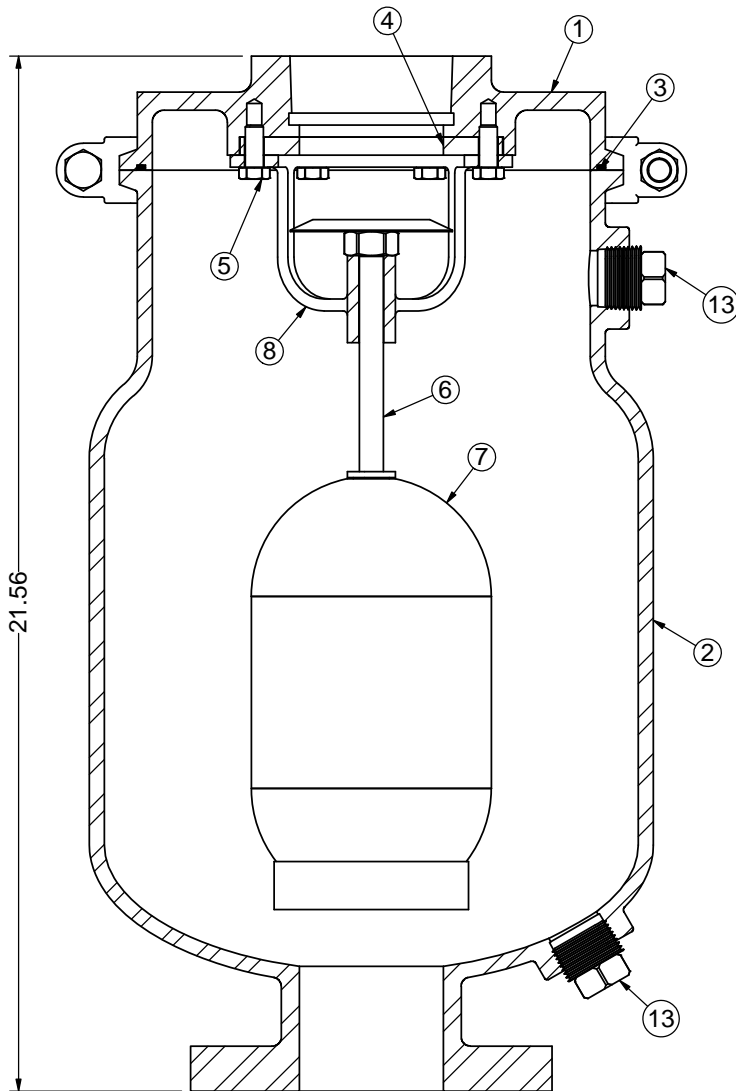

SECTION A-A

- NOTES:
1. INLET SIZE: 3" CLASS 150  
FLAT FACE FLANGE  
OUTLET SIZE: 3" NPT
  2. WORKING PRESSURE: 20-200 PSIG
  3. APPROXIMATE WEIGHT: 100 lbs

DO NOT SCALE DRAWING

DIMENSIONS ARE IN INCHES  
UNLESS OTHERWISE SPECIFIED:

FINISHED LINEAR TOLERANCES: ±0.015

UNFINISHED LINEAR TOLERANCE: +0.050/-0.020

FINISHED ANGULAR TOLERANCE: ±2°

Y:\ASSEMBLY\X Series\AX31\DRAWINGS\AX31

**Crispin Valves**

3" CLASS 150, X SERIES,  
AIR & VACUUM VALVE

SIZE DWG. NO. REV

C AX31 0

SCALE: 0.5:1 SHEET 1 OF 1

REV	DESCRIPTION	DATE	APPROVED

REVISIONS

DRAWN: B.J.L. DATE: 10-21-15

CHECKED: DJF DATE: 10-21-15