

PARTS LIST				
ITEM NO.	PART NUMBER	DESCRIPTION	MATERIAL	QTY.
1	36-U4X-2	COVER FLANGE	A351 GR. CF8M	1
2	28-3X-4F-2	BODY	A351 GR. CF8M	1
3	AS568A-272	FLANGE O-RING	BUNA-N RUBBER	1
4	29-16X	FLOAT GUIDE STAND	A351 GR. CF8M	1
5	36-A4X-5	SEAT	BUNA-N RUBBER	1
6	36-A4-6	VALVE	316 STAINLESS STEEL	1
7	HHCS.375X.88	SEAT RETAINER BOLT	316 STAINLESS STEEL	6
8	36-A3-9	FLOAT	316 STAINLESS STEEL	1
9	28-11X	CLAMP HALF	A351 GR. CF8M	2
10	HHCS.5X3.5	CLAMP BOLT	316 STAINLESS STEEL	2
11	LW.5	LOCK WASHER	316 STAINLESS STEEL	2
12	FHN.5-13	CLAMP NUT	316 STAINLESS STEEL	2
13	PLG1	PLUG	316 STAINLESS STEEL	2

4" CLASS 150 INLET FLANGE DATA	
FLANGE DIAMETER	9.00 in.
FLANGE THICKNESS	0.94 in.
BOLT CIRCLE DIAMETER	7.50 in.
NUMBER OF BOLT HOLES	8
BOLT HOLE SIZE	0.75 in.

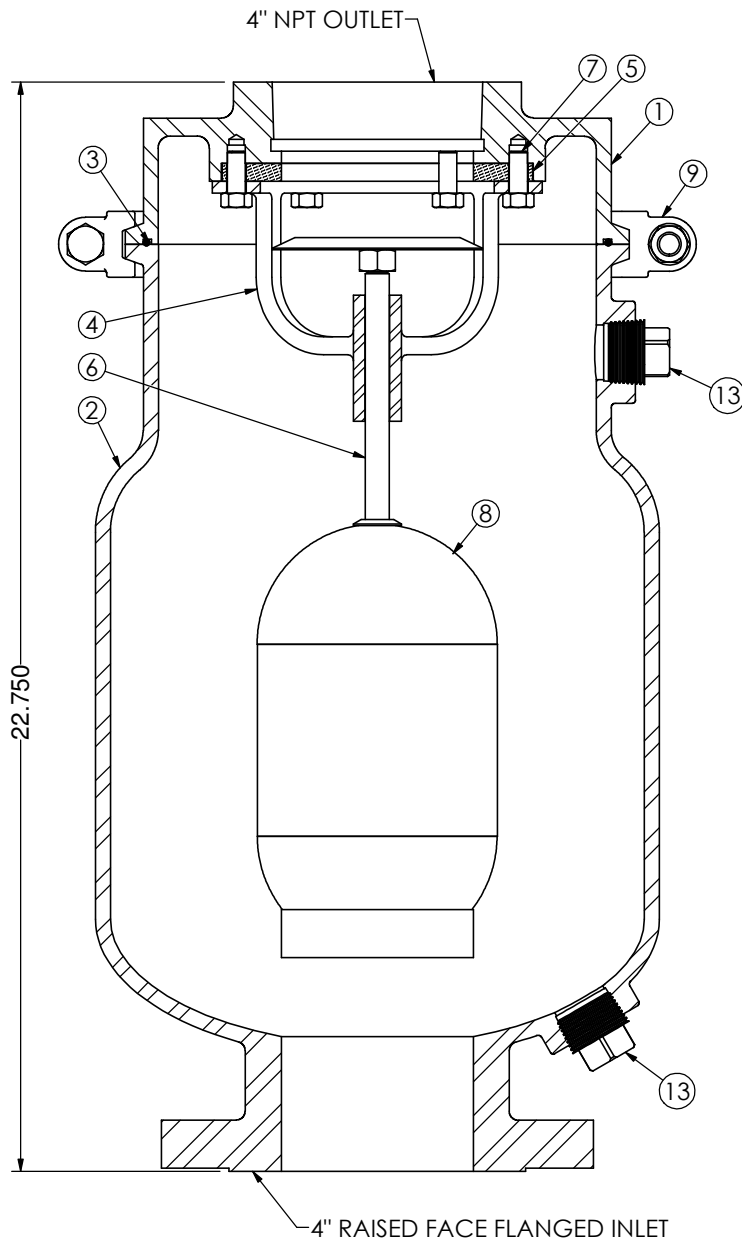

SECTION A-A

NOTES:

1. APPROXIMATE WEIGHT : 45 LBS.

CRISPIN VALVES

4" FLANGES AIR
RELEASE VALVE

REV	DATE	BY	APPD	REVISION	REDRAWN:		SIZE	DWG. NO.	REV
					CHECKED:		C	AX41	0
					DRAWN: C. GEARY				