



Globe Check Valves

THE GC SERIES:

Class 150 and Class 300 ANSI Flanged

- Sizes 3"-36" Available
- Prevents Flow Reversal • Fully Automatic • Spring Loaded • Double Guided



CRISPIN VALVE

SINCE 1905



600 FOWLER AVENUE,
BERWICK, PA 18603



(800) 247-8258
TEL. (570) 752-4524
FAX (570) 752-4962



WWW.CRISPINVALVE.COM
INFO@CRISPINVALVE.COM



GC SERIES SILENT CHECK VALVES

Preventing Flow Reversal to Limit Water Hammer and System Surges

Ideal for use on Municipal Water Systems, Industrial Class HVAC-Liquid Service applications, Industrial Piping Systems and Irrigation Systems, Crispin's Globe Check Series Silent Check Valves prevent flow reversal, which eliminates water hammer and system surges associated with valve closure. Fully automatic, spring-loaded and double-guided, the valves open as the pump starts, and close just prior to flow reversal upon pump outage. With standard ductile iron bodies, and 316 stainless steel disc, shaft, bushing and seat, all internal parts of the Globe Check Valves are field replaceable for ease of maintenance. In addition, the GC Series is designed so that a butterfly valve may be used downstream without the use of a space flange or spool piece. This feature is available in sizes thru 10".

The GC Series features a ductile iron body with flanged ends (Class 150 or Class 300) that bolt into a pipeline. Resilient Seats are also available, and are highly recommended for potable water or drip tight applications.

SERVICE APPLICATIONS

- ✓ Municipal Water Systems
- ✓ Industrial Class HVAC-Liquid Service
- ✓ Industrial Piping Systems
- ✓ Irrigation Systems

GC SERIES ADVANTAGES

- ✓ Limits the Effects of System Surges on Air Release Valves
- ✓ Available in Sizes 3"-36"
- ✓ CL 150: 250 PSI Maximum Working Pressure
CL 300: 640 PSI Maximum Working Pressure
- ✓ Ductile Iron Construction with Stainless Steel Trim Standard

PRESSURE TESTING

Sizes 3"-12"		
TEST	CLASS 150	CLASS 300
Non Shock Gage Pressure	300 PSI [20.7 BAR]	500 PSI [34.5 BAR]
Shell Test Pressure	375 PSI [25.9 BAR]	750 PSI [51.7 BAR]
Seat Test Pressure	250 PSI [17.2 BAR]	500 PSI [34.5 BAR]
Sizes 14"-36"		
TEST	CLASS 150	CLASS 300
Non Shock Gage Pressure	250 PSI [17.2 BAR]	400 PSI [27.6 BAR]
Shell Test Pressure	375 PSI [25.9 BAR]	600 PSI [41.4 BAR]
Seat Test Pressure	250 PSI [17.2 BAR]	400 PSI [27.6 BAR]

GC SERIES OPTIONS

- ✓ Aluminum & Bronze Trim Available
- ✓ Buna-N or Viton Resilient Seating Available
- ✓ Optional 2 Part High Solids Epoxy Coating
- ✓ AIS & Buy American Act Configurations

PRESSURE RATING

- ✓ ANSI B16.1
B.S. 4504
DIN PN 10, PN 16 and PN 25

MAX. TEMPERATURE RATING

- ✓ 150°F (65°C)

NOTE: Materials and prices are subject to change without notice. Metric and special class flange ratings are available.



GC SERIES FLOW CHARACTERISTICS AND PLACEMENT

GC Series Valves are intended for liquid service only. Consult factory for applications other than liquid.

Globe Check GC Series Head Loss Chart*

*Head loss charts are for flow when valve is positioned with the seat downstream. For sizes above 24", please contact the factory.

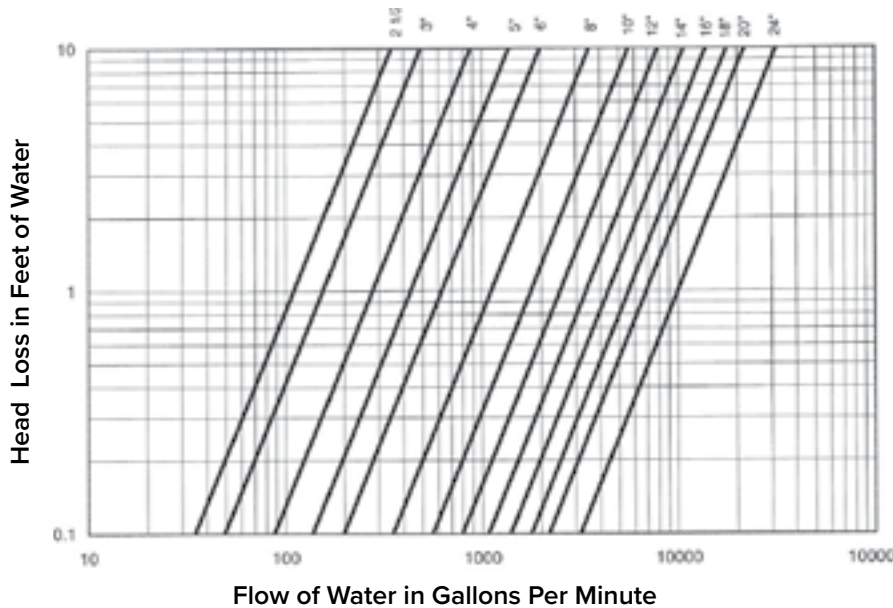

Special Maintenance Note:

The GC Series valve should never be inspected by only removing the valve inlet flange piping. If this is done, seat damage to the valve or personal injury to the inspector may occur. If the valve must be serviced, it should be isolated and the line pressure relieved on both sides of the valve. For additional instructions, consult the GS Series Operation & Maintenance manual at www.crispinvalve.com.

These valves are intended for use on municipal water systems, or approved commercial and/or industrial applications only.

Resilient Seats are highly recommended for Potable Water or Drip Tight Applications.

Flow Velocity



Globe Check Series valves have a maximum recommended flow velocity of 10 feet per second. In addition, flow curves are based on the flow of clean water at an ambient temperature.

Line Placement

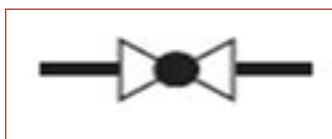

Piping standards recommend placing valves 5 to 10 pipe diameters from any turbulence producing devices (i.e. pumps, etc.) This recommendation should be followed to prevent increased valve wear or possible damage.

Valve Replacement

Existing swing check valves can be replaced with a GC Series valve. The replacement involves the addition of a spool piece to be bolted to the replacement valve. The entire assembly can be provided to conform to the existing valve's face to face dimension.

The GC Series is designed so that a butterfly valve may be used downstream without the use of a space flange or spool piece.

NOTE: Materials and prices are subject to change without notice. Metric and special class flange ratings are available.



GC SERIES GLOBE CHECK VALVE MATERIALS LIST

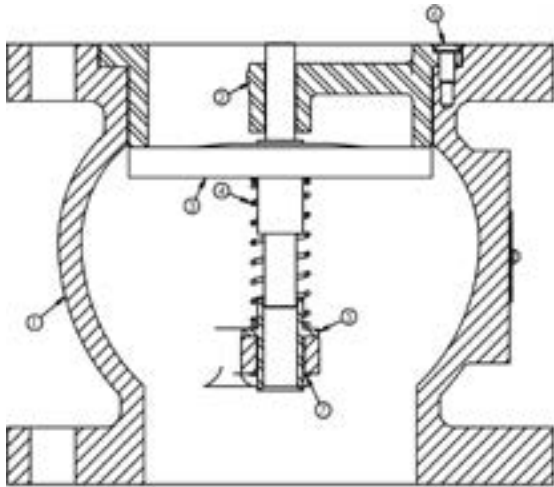

GC Series, 3"-4" Materials List		
ITEM	DESC.	MATERIAL
1	BODY	Ductile Iron
2	SEAT RING*	Stainless Steel
3	DISC	Stainless Steel
4	SPRING	Stainless Steel
5	BUSHING	Stainless Steel
6	SCREW	Stainless Steel
7	RETAINING RING	Stainless Steel

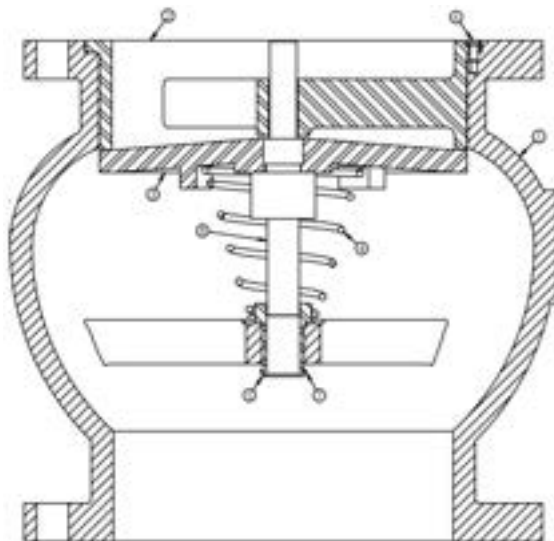

GC Series, 6"-18" Materials List		
ITEM	DESC.	MATERIAL
1	BODY	Ductile Iron
2	SEAT RING*	Stainless Steel
3	DISC	Stainless Steel
4	SPRING	Stainless Steel
5	BUSHING	Stainless Steel
6	SCREW	Stainless Steel
7	RETAINING RING	Stainless Steel
8	SHAFT	Stainless Steel

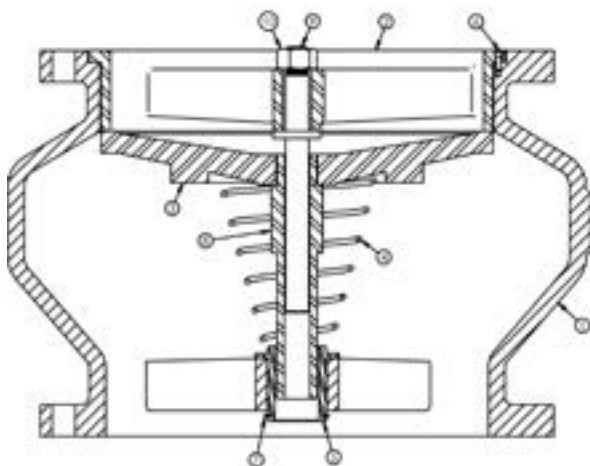

GC Series, 20"-36" Materials List		
ITEM	DESC.	MATERIAL
1	BODY	Ductile Iron
2	SEAT RING*	Stainless Steel
3	DISC	Stainless Steel
4	SPRING	Stainless Steel
5	BUSHING	Stainless Steel
6	SCREW	Stainless Steel
7	RETAINING RING	Stainless Steel
8	SHAFT	Stainless Steel
9	SEAT SHAFT	Stainless Steel
10	SHAFT NUT	Stainless Steel

* For Valves with a Resilient Seat, the Seat Rings are Buna-N Rubber and Stainless Steel, or optional Viton.

NOTE: Materials and prices are subject to change without notice. Metric and special class flange ratings are available.



GC SERIES GLOBE CHECK VALVE DIMENSIONAL INFO

Please note that the inside diameter of the mating flange must overlap the valve seat in order to provide proper seat retention. The flange gasket must be sized in order to provide a seal between the internal diameter of the valve body and the outside diameter of the seat.

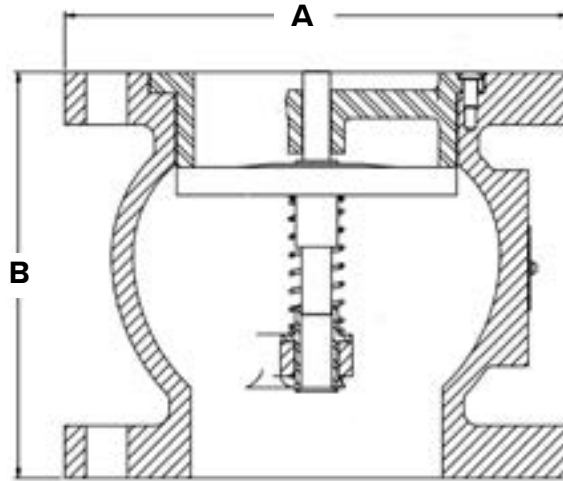

For dimensional information on size 2 1/2" or sizes above 24", please contact the factory directly.

**** GC Series sizes 12", 16" and 20" have shaft protrusions that should be accounted for during installation:**
12"-shaft protrusion of .74"
16"-shaft protrusion of 1.62"
20"- shaft protrusion of 3.62"

GC Series, 3"-24"* Size Specifications

DIMENSIONS ARE IN INCHES. CERTIFIED DIMENSIONS AVAILABLE.

VALVE SIZE	MODEL # STD TRIM SEAT	MODEL # RESILIENT SEAT	ANSI CLASS FLANGE	FACE TO FACE (B)	MAXIMUM DIAMETER (A)	WEIGHT (LBS)	NUMBER OF BOLTS
3	GC31	GC31.R	150	6.00	7.50	29	4
3	GC33	GC33.R	300	6.00	8.25	32	8
4	GC41	GC41.R	150	7.25	9.00	44	8
4	GC43	GC43.R	300	7.25	10.00	49	8
6	GC61	GC61.R	150	9.75	11.00	72	8
6	GC63	GC63.R	300	9.75	12.50	101	12
8	GC81	GC81.R	150	12.50	13.62	126	8
8	GC83	GC83.R	300	12.50	15.00	174	12
10	GC101	GC101.R	150	15.50	16.87	185	12
10	GC103	GC103.R	300	15.50	17.50	275	16
12	GC121	GC121.R	150	14.25**	20.63	308	12
12	GC123	GC123.R	300	14.25**	20.50	389	16
14	GC141	GC141.R	150	15.75	22.50	380	12
14	GC143	GC143.R	300	15.75	23.00	441	20
16	GC161	GC161.R	150	17.63**	23.50	525	16
16	GC163	GC163.R	300	17.63**	26.41	658	20
18	GC181	GC181.R	150	18.75	28.00	725	16
18	GC183	GC183.R	300	18.75	28.00	825	24
20	GC201	GC201.R	150	20.63**	31.25	815	20
20	GC203	GC203.R	300	20.63**	31.25	1061	24
24	GC241	GC241.R	150	24.00	37.00	1540	20
24	GC243	GC243.R	300	24.00	37.00	1650	24

NOTE: Materials and prices are subject to change without notice. Metric and special class flange ratings are available.



GC SERIES GLOBE CHECK VALVES SPECIFICATION

GC Series, Sizes 3"-36"

GENERAL

GC Series Silent Globe Check Valves shall fully automatic, spring loaded and double guided. The valve shall open as the pump starts and close just prior to flow reversal upon pump outage.

BODIES

The valve(s) shall be _____" ANSI Class (150, 300) flanged, ductile iron construction with stainless steel seat, disc, bushing and spring. All internal parts shall be field replaceable for ease of maintenance.

These valves are intended for use on municipal water systems, or approved commercial and/or industrial applications only. An optional Resilient Seat in Buna-N Rubber or Viton should be order for potable water or drip tight applications.

ACCEPTABLE MANUFACTURERS

The valve(s) shall be Crispin Model _____ as manufactured by Crispin-Multiplex Manufacturing Co., Berwick, PA.



NOTE: Materials and prices are subject to change without notice. Metric and special class flange ratings are available.