

LUDLOW-RENSSELAER

AWWA C-515

RESILIENT WEDGE GATE VALVE

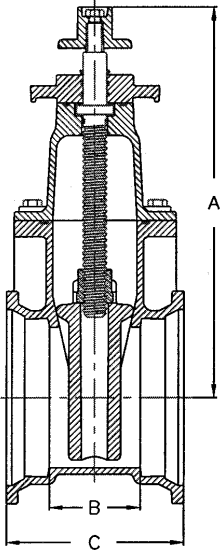

M.J. x M.J.

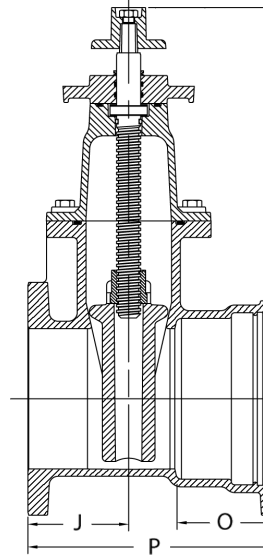

TYTON® x FLANGE

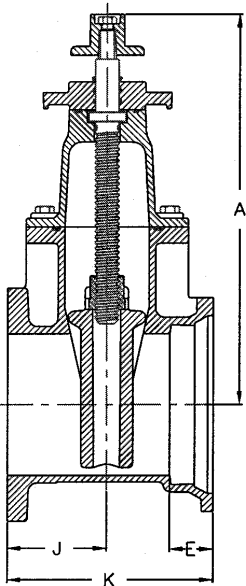

M.J. x FLANGE

VALVES FROM 2" THRU 24"

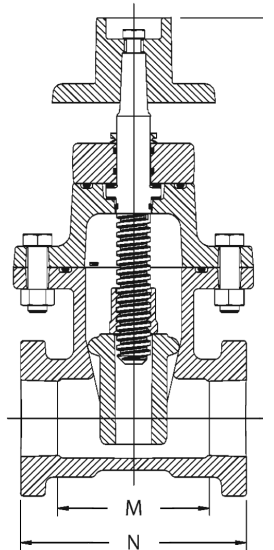

THD. x THD.

PO Box 411
Berwick, PA 18603

570-752-4524
www.crispinvalve.com

2" - 16" LUDLOW-RENSSELAER RESILIENT WEDGE GATE VALVE

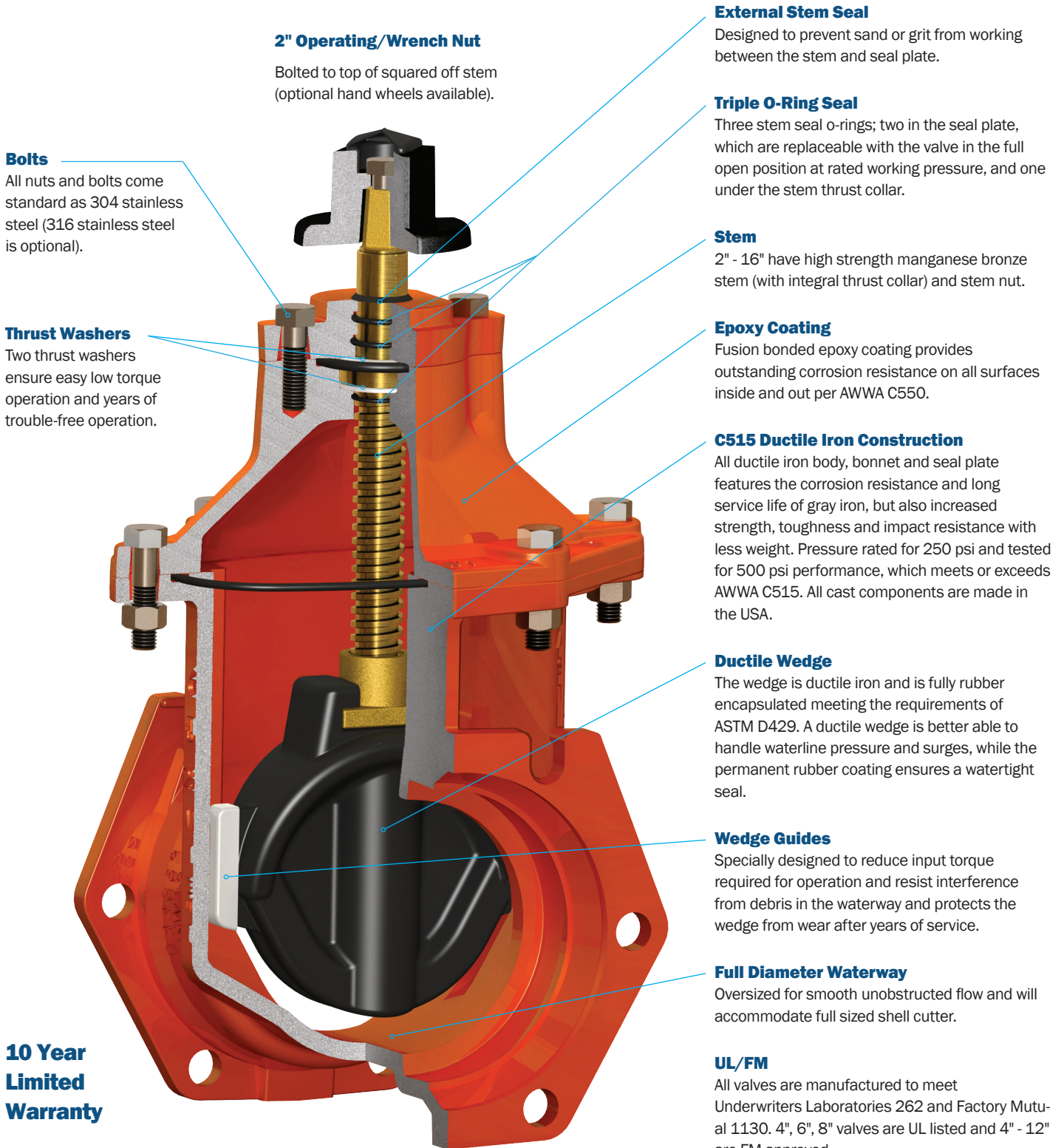

2" Operating/Wrench Nut

Bolted to top of squared off stem (optional hand wheels available).

Bolts

All nuts and bolts come standard as 304 stainless steel (316 stainless steel is optional).

Thrust Washers

Two thrust washers ensure easy low torque operation and years of trouble-free operation.

External Stem Seal

Designed to prevent sand or grit from working between the stem and seal plate.

Triple O-Ring Seal

Three stem seal o-rings; two in the seal plate, which are replaceable with the valve in the full open position at rated working pressure, and one under the stem thrust collar.

Stem

2" - 16" have high strength manganese bronze stem (with integral thrust collar) and stem nut.

Epoxy Coating

Fusion bonded epoxy coating provides outstanding corrosion resistance on all surfaces inside and out per AWWA C550.

C515 Ductile Iron Construction

All ductile iron body, bonnet and seal plate features the corrosion resistance and long service life of gray iron, but also increased strength, toughness and impact resistance with less weight. Pressure rated for 250 psi and tested for 500 psi performance, which meets or exceeds AWWA C515. All cast components are made in the USA.

Ductile Wedge

The wedge is ductile iron and is fully rubber encapsulated meeting the requirements of ASTM D429. A ductile wedge is better able to handle waterline pressure and surges, while the permanent rubber coating ensures a watertight seal.

Wedge Guides

Specially designed to reduce input torque required for operation and resist interference from debris in the waterway and protects the wedge from wear after years of service.

Full Diameter Waterway

Oversized for smooth unobstructed flow and will accommodate full sized shell cutter.

**10 Year
Limited
Warranty**

End Connections

Available in 2" - 24" sizes. See page 15 for available end connections.

UL/FM

All valves are manufactured to meet Underwriters Laboratories 262 and Factory Mutual 1130. 4", 6", 8" valves are UL listed and 4" - 12" are FM approved.

NSF

Certified to NSF/ANSI Standard 61 & 372.

2" - 16" LUDLOW-RENSELAER VALVE PARTS

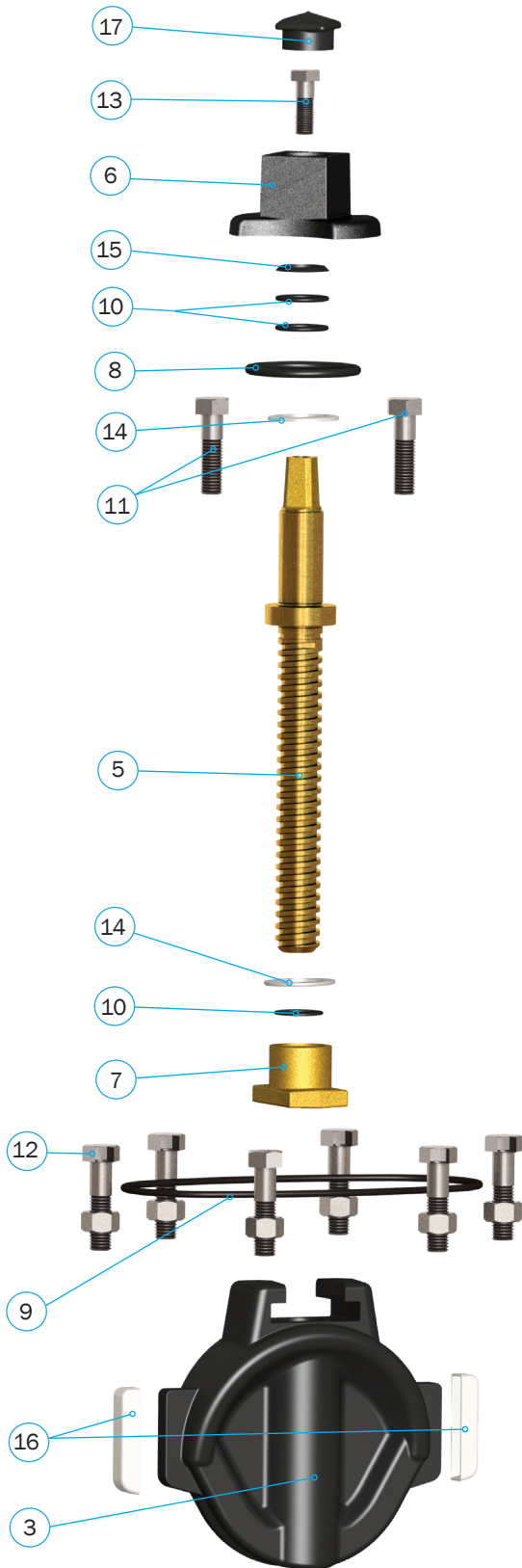

Ludlow-Rensselaer Valve Parts

Item No.	Qty.	Part Name and Description	Material
1*	1	Body	Ductile Iron
2*	1	Bonnet	Ductile Iron
3	1	Rubber Encapsulated Ductile Wedge	Ductile Iron/ Synthetic Rubber
4*	1	Seal Plate	Ductile Iron
5	1	Stem	Manganese Bronze
6	1	Operating Nut	Gray Iron
7	1	Stem Nut	Manganese Bronze
8	1	Seal Plate O-ring	Rubber, Buna-N
9	1	Bonnet O-ring	Rubber, Buna-N
10	3	Stem O-rings	Rubber, Buna-N
11	1	Seal Plate Bolts	Stainless Steel
12	1	Bonnet Bolts/Nuts	Stainless Steel
13	1	Large Hex Cap Screw	Stainless Steel
14	2	Thrust Washers	Polymer
15	1	External Stem Seal	Rubber, Buna-N
16	1	Wedge Guides	Polymer
17	1	Dust Cap	Rubber

* Not Shown

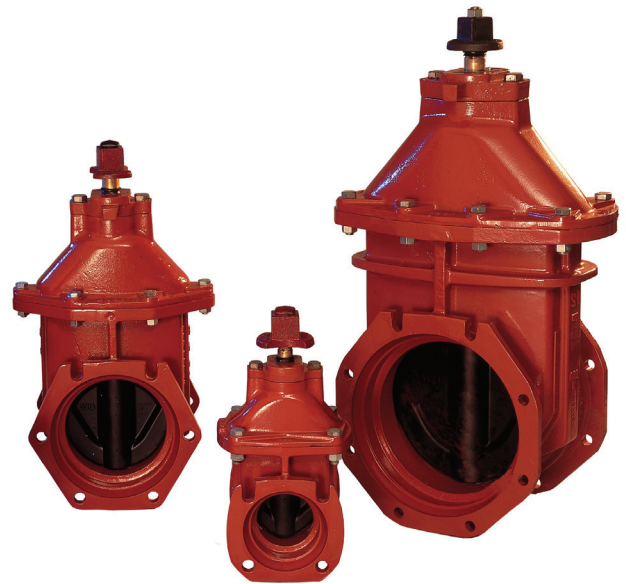

Ludlow-Rensselaer valves incorporate quality parts and a simple design. Each valve is inspected and individually tested.

All Ludlow-Rensselaer valves are made and assembled in the USA.

20" & 24" LUDLOW-RENSSELAER RESILIENT WEDGE GATE VALVE

Options

- Bevel gear operator
- Spur gear operator
- Handwheel
- 2" AWWA operating nut

End Connections

- MJ x MJ
- FE x FE
- MJ x FE
- MJ x TAP



Installation of 24" Resilient Wedge Gate Valve

AWWA C515

The all ductile iron body, bonnet and seal plate resists corrosion and offers the same long service life as gray iron, but with less weight. It has increased strength, toughness and impact resistance. Each valve is pressure rated for 250 psi and tested for 500 psi performance which meets or exceeds AWWA C515.

Stem

The stem is made of high strength 304 stainless steel and is lead free.

Wedge Guides

Specially designed wedge guides reduce input torque required for operation. The guides also resist interference from debris in the waterway and protect the wedge from wear after years of service.

Full Diameter Waterway

The full diameter waterway is oversized providing a smooth unobstructed flow and also accommodates a full sized shell cutter.

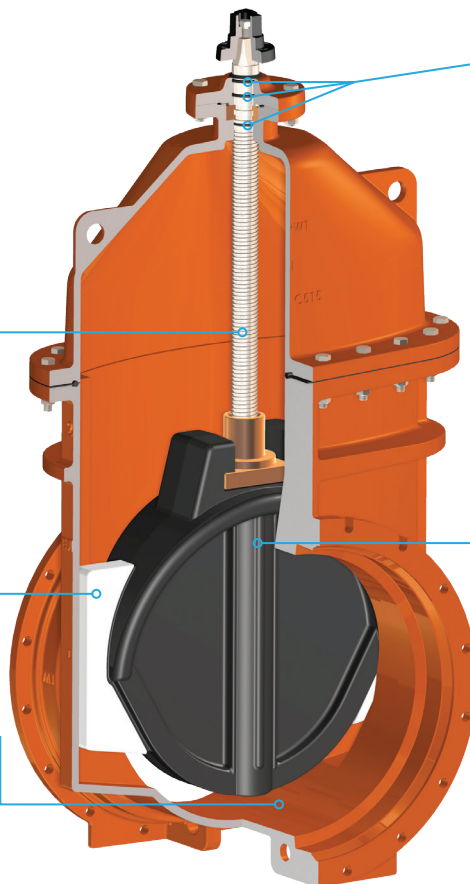

Triple O-Ring Seal

Three stem seal o-rings; two in the seal plate, which are replaceable with the valve in the full open position at rated working pressure, and one under the stem thrust collar.

Epoxy Coating

Fusion bonded epoxy coating provides outstanding corrosion resistance on all surfaces inside and out per AWWA C550 and is NSF 61 certified.

Ductile Wedge

The ductile iron wedge is rubber encapsulated which meets the requirements of ASTM D429. A ductile wedge is better able to handle waterline pressure and surges, while the permanent rubber coating ensures a watertight seal.

Bolts

All standard nuts and bolts are made of 304 stainless steel (316 stainless steel is optional).

**10 Year
Limited Warranty**

LUDLOW-RENSELAER GATE VALVE DIMENSIONS AND AVAILABLE END CONNECTIONS

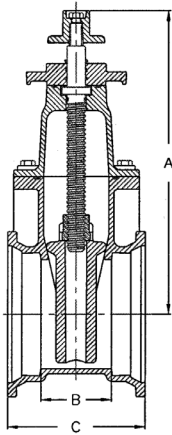

M.J. x M.J.

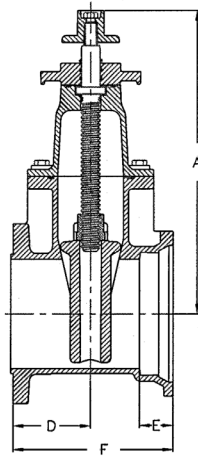

M.J. x TAPPING

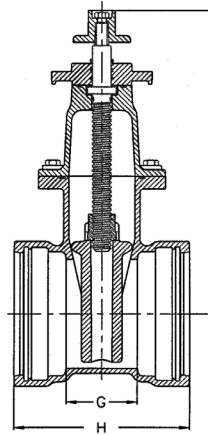

TYTON® x TYTON®

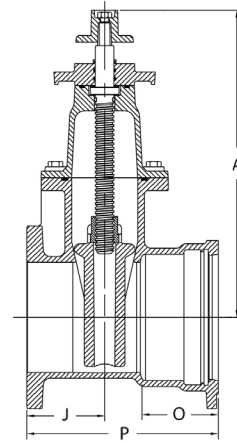

TYTON® x FLANGE

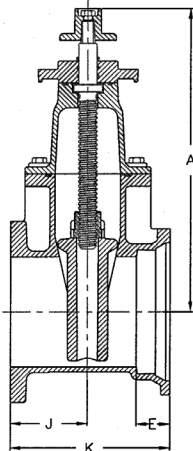

M.J. x FLANGE

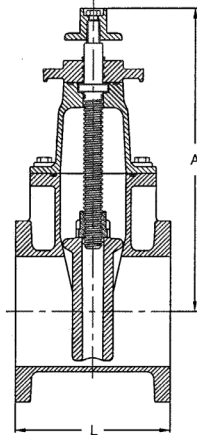

FLANGE x FLANGE

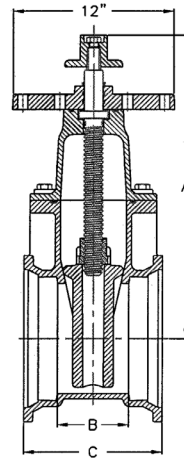

M.J. x M.J.
INDICATOR POST VALVE

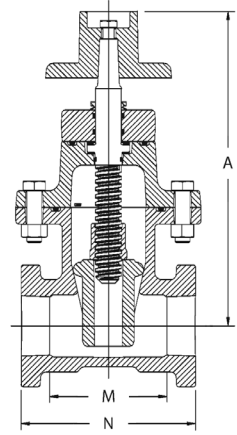

THD. x THD.

Ludlow-Rensselaer Gate Valve Dimensions and Available End Connections

Size	A	B	C	D	E	F	G	H	J	K	L	M	N	O	P	Open Turns
2"	10 5/8	3 1/2	8 1/2									3 7/8	5 7/8			10
3"	13 1/8	4 3/4	9 3/4													14
4"	15	4 5/16	9 5/16	5 1/16	2 1/2	10 5/16	4 3/8	11	5 1/16*	10 5/16	9			4 1/8	10 15/16	17
6"	18 9/16	4	9	5 1/4	2 1/2	11 1/4	4	11 1/8	5 1/4	11 1/4	10 1/2			4 3/8	11 3/4	20
8"	22 11/16	5 1/4	10 1/4	5 3/4	2 1/2	11 7/8	5 1/4	13	5 3/4	11 7/8	11 1/2			5 5/8	14 1/8	26
10"	27	6 7/8	11 5/8	6 1/2	3 1/2	13 1/2	6 7/8	15 5/8	6 1/2	13 1/2	13			5 5/8	15 9/16	32
12"	31 1/8	8	13	7	2 1/2	14 3/4	8	16 1/2	7	14 3/4	14			5 5/8	16 11/16	38
16"	39 1/2	14 1/2	21 3/4	8 1/2	3 1/2	19 3/8	10 5/8	21	8 1/2	19 3/8	17					51
20"	48 7/16	11	18	9	3 1/2	18				18	18					62
24"	57	16	23	10	3 1/2	21 1/2				21 1/2	20					74

Note: All dimensions are in inches.

TYTON® is a registered trademark of U.S. Pipe.

* 4" TYTON® x FLANGE is 4 1/2"

2" - 16" LUDLOW-RENSELAER RESILIENT WEDGE GATE VALVES SAMPLE SPEC

Valves shall be manufactured and tested to meet the requirements of ANSI/AWWA C515. Valves shall meet or exceed the requirements of Underwriters Laboratories Standard UL262 and Factory Mutual Standard 1130.

Valves shall be certified to NSF/ANSI 61 & 372.

The rated working pressure of the valve shall be 250 psi.

All valve component castings shall originate in the USA.

The body, bonnet, wedge and seal plate shall be made of ductile iron in accordance with ASTM A536. The wedge shall be totally encapsulated in rubber. This rubber coating shall be permanently bonded to the ductile iron wedge casting and shall meet ASTM D429 tests for rubber to metal bonding. No paint shall be allowed in the wedge and the wedge must not be hollow. Containment of the stem nut must only be on two sides to facilitate easy removal.

There shall be three stem seal o-rings; two in the seal plate which shall be replaceable with the valve in the full open position at rated working pressure, and one under the stem thrust collar. All gaskets shall be o-ring seals. O-rings set in a cartridge shall not be allowed. A grit seal must be present above the seal plate to prevent dirt intrusion.

Valves are to be open left (OL) or open right (OR). Operating nuts are to be painted black (OL) or painted red (OR). The NRS valves shall be

provided with a 2" square operating nut (2"-24").

2" - 16" valves must have two polymer thrust washers — one above and one below the thrust collar. Stainless steel thrust washers are not acceptable.

All fasteners are to be 304 stainless steel. Socket head bolts shall not be allowed. If only two bolts are used to secure the seal plate, the bolts must be fastened to the bonnet with a drilled and tapped hole in the bonnet.

The body, bonnet and seal plate shall be epoxy coated in accordance with ANSI/AWWA C550 certified to NSF 61. This coating shall be on the interior and the exterior of the valve. The manufacturers name, valve size, year of manufacture, pressure rating ("250W"), C515 and "DI" shall be cast on the valve.

Each valve shall be tested in accordance with ANSI/AWWA C515, UL262 and FM1130. This shall include hydrostatic pressure testing at 500 psi. A certification of manufacture and testing shall be provided at the municipality's request.

All parts of valves to be considered must be manufactured, assembled and tested in the contiguous USA, and letters of certification must accompany any and all products at the request of municipality.

Valves shall be Ludlow-Rensselaer.

20" & 24" LUDLOW-RENSELAER RESILIENT WEDGE GATE VALVES SAMPLE SPEC

Valves shall be manufactured and tested to meet the requirements of ANSI/AWWA C515. Valves shall meet or exceed the requirements of Underwriters Laboratories Standard UL262 and Factory Mutual Standard 1130.

The rated working pressure of the valve shall be 250 psi.

All valve component castings shall originate in the USA.

The body, bonnet, wedge and seal plate shall be made of ductile iron in accordance with ASTM A536. The wedge shall be totally encapsulated in rubber. This rubber coating shall be permanently bonded to the ductile iron wedge casting and shall meet ASTM D429 tests for rubber to metal bonding. No paint shall be allowed in the wedge and the wedge must not be hollow. Containment of the stem nut must only be on two sides to facilitate easy removal.

There shall be three stem seal o-rings; two in the seal plate which shall be replaceable with the valve in the full open position at rated working pressure, and one under the stem thrust collar. All gaskets shall be o-ring seals. O-rings set in a cartridge shall not be allowed. A grit seal must be present above the seal plate to prevent dirt intrusion.

Valves are to be open left (OL) or open right (OR). Operating nuts are to be painted black (OL) or painted red (OR). The NRS valves shall be provided with a 2" square operating nut (2"-24").

All valves 20" or larger must incorporate a high strength 304 stainless steel stem that is lead free.

All fasteners are to be 304 stainless steel. Socket head bolts shall not be allowed. If only two bolts are used to secure the seal plate, the bolts must be fastened to the bonnet with a drilled and tapped hole in the bonnet.

The body, bonnet and seal plate shall be epoxy coated in accordance with ANSI/AWWA C550 certified to NSF 61. This coating shall be on the interior and the exterior of the valve. The manufacturers name, valve size, year of manufacture, pressure rating ("250W"), C515 and "DI" shall be cast on the valve.

Each valve shall be tested in accordance with ANSI/AWWA C515, UL262 and FM1130. This shall include hydrostatic pressure testing at 500 psi. A certification of manufacture and testing shall be provided at the municipality's request.

All parts of valves to be considered must be manufactured, assembled and tested in the contiguous USA, and letters of certification must accompany any and all products at the request of municipality.

Valves shall be Ludlow-Rensselaer.