

# Materials List, 3"-20" AL/SC/PL Series Surge Check Valve

## AL/SC/PL SERIES, 3"-20" SIZES MATERIALS LIST

Drawing is for representational purposes only. Materials & configurations will change depending on valve size.

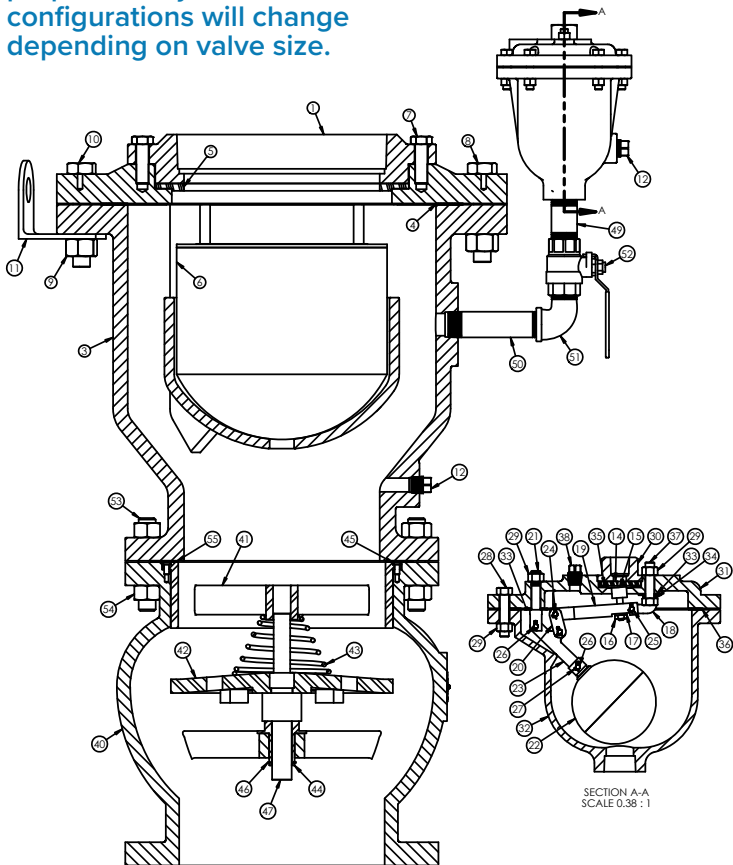

AL Series Materials List		
ITEM	DESC.	MATERIAL
1	TOP	Cast Iron (A126 CL B)
2	COVER FLANGE	Cast Iron (A126 CL B)
3	BODY	Cast Iron (A126 CL B)
4	COVER GASKET	Armstrong N-8092
5	SEAT	Buna-N Rubber (D2000)
6	FLOAT	Stainless Steel (A240)
7	TOP BOLT	Steel (A307)
8	COVER BOLT	Steel (A307)
9	COVER NUT	Steel (A563)
10	LUG BOLT	Steel (A307)
11	LIFTING LUG	Steel (A36)
12	BODY PLUG	Brass (B505)

PL Series Materials List		
ITEM	DESC.	MATERIAL
14	PRESSURE SEAT	PVC
15	VALVE PLUNGER	Buna-N & Stainless Steel
16	PLUNGER NUT	Stainless Steel
17	LOCK WASHER	Stainless Steel
18	VALVE FULCRUM	Stainless Steel
19	VALVE LEVER	Stainless Steel
20	LINK	Stainless Steel
21	FLOAT FULCRUM	Stainless Steel
22	FLOAT	Stainless Steel
23	FLOAT LEVER	Stainless Steel
24	BEARING PIN	Stainless Steel
25	BEARING PIN	Stainless Steel
26	BEARING PIN	Stainless Steel
27	COTTER PIN	Stainless Steel
28	COVER BOLT	Steel
29	COVER NUT	Steel
30	TOP	Cast Iron
31	COVER FLANGE	Cast Iron
32	BODY	Cast Iron
33	FULCRUM WHSR	Fiber
34	FULCRUM WHSR	Fiber
35	PRES SEAT GSKT	Buna-N Rubber
36	COVER GASKET	Armstrong
37	FULCRUM BOLT	Steel
38	FLANGE PLUG	Brass

SC Series Materials List		
ITEM	DESC.	MATERIAL
40	BODY	Ductile Iron (ASTM A536)
41	SEAT RING	Stainless Steel
42	DISC	Stainless Steel
43	SPRING	Stainless Steel
44	BUSHING	Stainless Steel
45	SCREW	Stainless Steel
46	RETAINING RING	Stainless Steel
47	SHAFT	Stainless Steel

Connecting Parts Materials List		
ITEM	DESC.	MATERIAL
49	NIPPLE	Steel
50	NIPPLE	Steel
51	STREET ELBOW	Malleable Iron
52	BALL VALVE	Brass
53	FLANGE STUD	Steel
54	FLANGE NUT	Steel
55	FLANGE GASKET	Armstrong



<b>PRODUCT LINE</b> AL/SC/PL Series, 3"-20"  <b>SHEET</b> AL/SC/PL Series Materials List	<b>DATE</b> <b>REVISION</b> 12/18/2023                      0  <b>DOC. NO.</b> D-AV-ALSCPL-ML-r0
--	--