

C Series, Combination Air Release Valves, Sizes 1/2"-24", AWWA C512

C Series Combination Air Release Valve, Size 1"

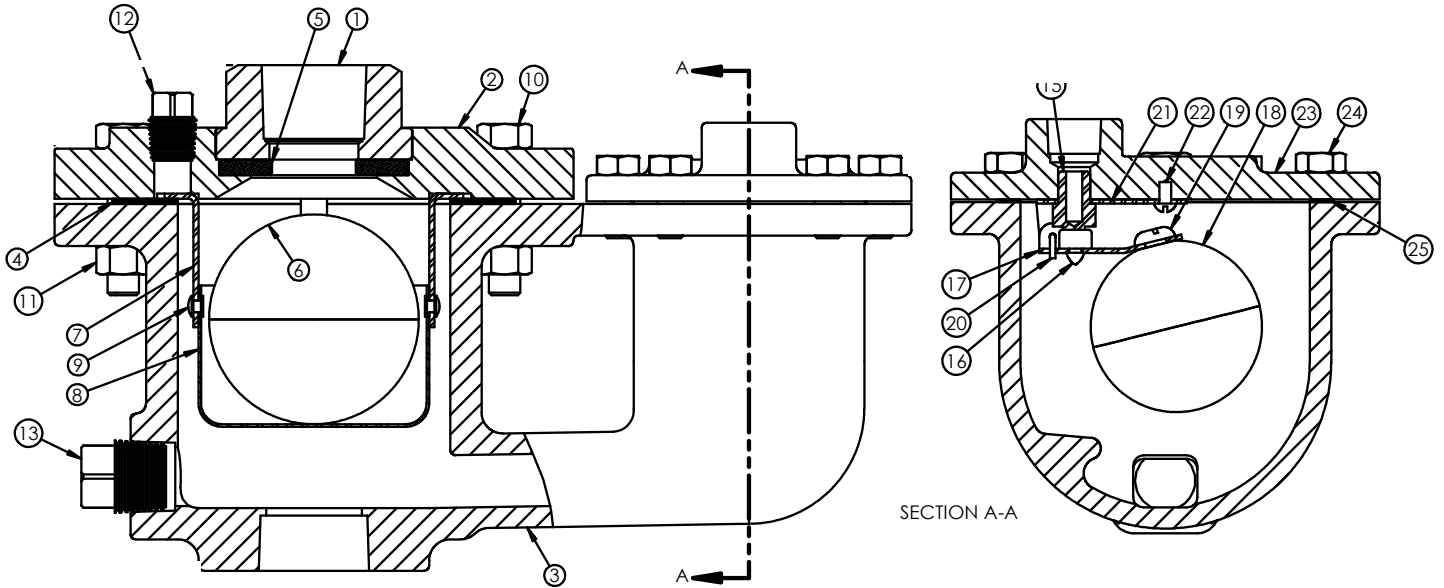

C SERIES, 1" SIZE MATERIALS LIST

Air & Vacuum Unit		
ITEM	DESC.	MATERIAL
1	TOP	Cast Iron
2	COVER FLANGE	Cast Iron
3	COMBO BODY	Cast Iron
4	COVER GASKET	Armstrong
5	AIR/VAC SEAT	Buna-N-Rubber
6	FLOAT	Stainless Steel
7	HANGER	Stainless Steel
8	CUP	Stainless Steel
9	RIVET	Stainless Steel
10	COVER BOLT	Stainless Steel
11	COVER NUT	Stainless Steel
12	FLANGE PLUG	Stainless Steel
13	BODY PLUG	Stainless Steel

Pressure Air Release Unit		
ITEM	DESC.	MATERIAL
15	PRESSURE SEAT	Stainless Steel
16	VALVE BUTTON	Viton
17	VALVE LEVER	Stainless Steel
18	FLOAT	Stainless Steel
19	FLOAT SCREW	Stainless Steel
20	HINGE PIN	Stainless Steel
21	HINGE BUTT	Stainless Steel
22	DRIVE SCREW	Stainless Steel
23	COVER FLANGE	Cast Iron
24	COVER BOLT	Steel
26	COVER GASKET	Armstrong

C Series, 1" Size Specifications

ALL DIMENSIONS ARE IN INCHES. CERTIFIED DIMENSIONS ALSO AVAILABLE.

Model	Inlet Size	Outlet Size	Overall Width	Overall Height	Weight (lbs)
C10	1 NPT	1 NPT	10.22	6.03	21



PRODUCT LINE C Series Combo. Air Release Valves, 1/2"-24	DATE 8/30/2023	REVISION 0
SHEET C Series Materials List, size 1"	DOC. NO. D-AV-C-1-ML-r0	