

Materials List/Dimensional Data for Air & Vacuum AX Series, AWWA C-512, 2"-6"

AX SERIES: SIZES 2-6" AVAILABLE

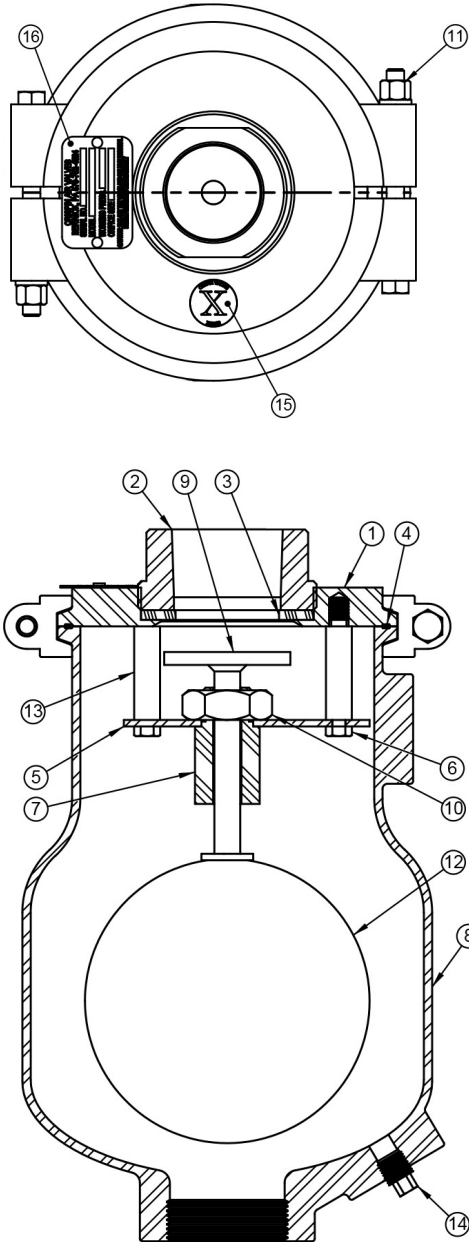

Air & Vacuum Assembly for Water & Wastewater Applications



PARTS LIST

ITEM	DESCRIPTION	MATERIAL	QTY
1	FLANGE	316 Stainless Steel	1
2	TOP	316 Stainless Steel	1
3	SEAT	Buna-N Rubber	1
4	FLANGE O-RING	Buna-N Rubber	1
5	STAND	316 Stainless Steel	1
6	STAND BOLTS	316 Stainless Steel	3
7	ROD GUIDE	Nylatron	1
8	BODY	316 Stainless Steel	1
9	VALVE	316 Stainless Steel	1
10	JAM NUT	316 Stainless Steel	1
11	CLAMP ASSEMBLY	316 Stainless Steel	1
12	FLOAT	316 Stainless Steel	1
13	STAND ROD	316 Stainless Steel	3
14	PLUG	316 Stainless Steel	1
15	RED ID DOT	Aluminum	1
16	BLUE TAG	Aluminum	1

SIZING AND SPECIFICATIONS

MODEL	SIZE"	INLET"	OUTLET"	H"	W"	WTlb
AX20	2	2 NPT	1 NPT	13.50	8.38	26
AX21	2	2 CL150	1 NPT	16.50	8.38	31
AX20-2	2	2 NPT	2 NPT	13.75	8.38	27
AX21-2	2	2 CL150	2 NPT	16.50	8.38	31
AX30	3	3 NPT	3 NPT	21.13	13.25	88
AX31	3	3 CL150	3 NPT	21.63	13.25	95
AX40	4	4 NPT	4 NPT	22.13	13.25	94
AX41	4	4 CL150	4 NPT	22.75	13.25	110
AX61	6	6 CL150	6 NPT	26.88	13.25	132

Standard Working Pressure: 2-150psi

Certified Dimensions Available Upon Request.



PRODUCT LINE	DATE	REVISION
X Series 316 SS Air Valve, Sizes 2"-6"	12/6/22	0
SHEET	DOC. NO.	
Materials List/Dimensions for AX Assembly	DW-AV-AX-ML+DIMS-r0	