

Materials List/Dimensional Data for Air & Vacuum PX Series, AWWA C-512, 2"-4"

PX SERIES: SIZES 2-4" AVAILABLE

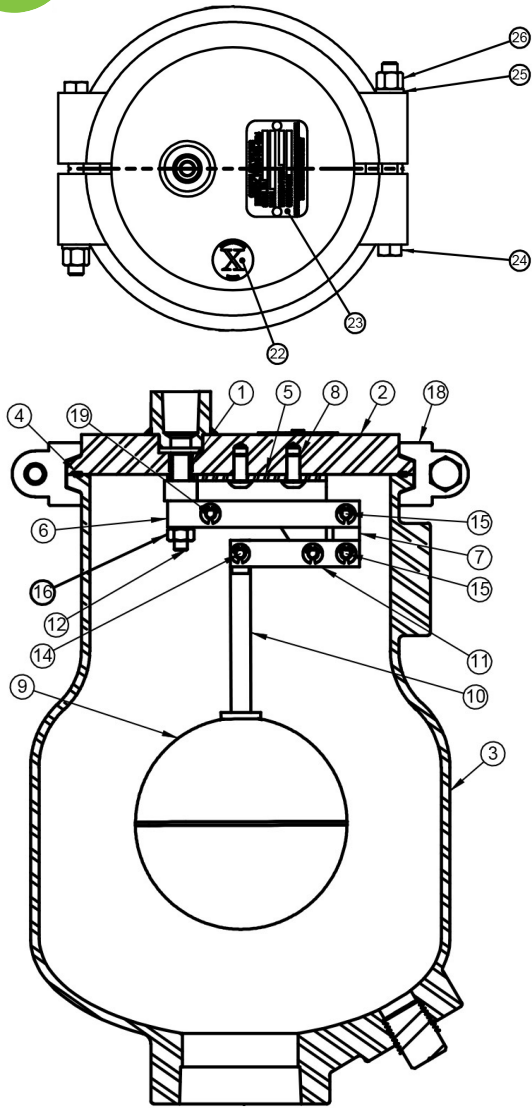

Pressure Air Release Assembly for Water & Wastewater Applications



PARTS LIST

ITEM	DESCRIPTION	MATERIAL	QTY
1	VALVE SEAT	316 Stainless Steel	1
2	FLANGE	316 Stainless Steel	1
3	BODY	316 Stainless Steel	1
4	FLANGE O-RING	Buna-N Rubber	1
5	FULCRUM ASSEMBLY	316 Stainless Steel	1
6	PLUNGER LEVER	316 Stainless Steel	1
7	LINK	316 Stainless Steel	2
8	CAP SCREW	316 Stainless Steel	2
9	FLOAT	316 Stainless Steel	1
10	FLOAT ROD	316 Stainless Steel	1
11	FLOAT LEVER	316 Stainless Steel	1
12	PLUNGER	Buna N/316 SS	1
14	BEARING PIN	316 Stainless Steel	1
15	BEARING PIN	316 Stainless Steel	2
16	PLUNGER NUT	316 Stainless Steel	1
18	CLAMP HALF	316 Stainless Steel	2
19	RETAINING RING	PH15-7 MO SS	5
20	PLUG	316 Stainless Steel	1
21	STREET ELBOW	316 Stainless Steel	1
22	GREEN ID DOT	ALUMINUM	1
23	TAG	ALUMINUM	1
24	HEX BOLT	316 Stainless Steel	2
25	LOCKWASHER	316 Stainless Steel	2
26	HEX NUT	316 Stainless Steel	2

SIZING AND SPECIFICATIONS

MODEL	SIZE"	INLET"	OUTLET"	H"	W"	WTlb
PX20	2	2 NPT	3/8 NPT	13.50	8.38	26
PX21	2	2 CL150	3/8 NPT	16.25	8.38	30
PX20-2	2	2 NPT	1/2 NPT	13.13	11.00	40
PX21-2	2	2 CL150	1/2 NPT	15.13	11.00	44
PX30	3	3 NPT	1 NPT	20.38	13.25	72
PX31	3	3 CL150	1 NPT	20.88	13.25	96
PX40	4	4 NPT	1 NPT	20.38	13.25	74
PX41	4	4 CL150	1 NPT	20.88	13.25	103

ORIFICE DATA

MODEL	ORIFICE DIAMETER	STAN. OPERATING PRESSURE
PX20	3/16"	20-200psi
PX20-2	3/16"	20-200psi
PX31	3/8"	20-150psi
PX41	3/8"	20-150psi

Certified Dimensions Available Upon Request.



PRODUCT LINE X Series 316 SS Air Valve, Sizes 2"-6"	DATE 12/6/22	REVISION 0
SHEET Materials List/Dimensions for PX Assembly	DOC. NO. DW-AV-PX-ML+DIMS-r0	