

Submittal Sheet for Crispin FV Series

2"-4" Threaded Foot Valve

Date: 2016

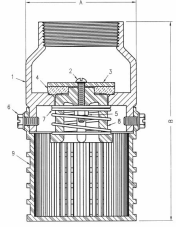

Specifications

Foot Valve(s) shall be installed on the pump suction to prevent the pump column from draining upon pump shutdown.

The valve(s) shall be silent operating and normally closed. A center guided disc with a Buna-N seat shall provide a drip tight seal. Minimum flow area perpendicular to the direction of flow thru the valve shall be equal to the pipe area. The inlet shall be fitted with a polypropylene screen with a clear opening adequate to provide 3 to 4 times the area of the pipe.

2"-4" threaded: The valve(s) materials of construction shall include a cast iron body, stainless steel spring, Delrin and stainless steel poppet, Nitrile seat, and polypropylene strainer. The pipe connection shall be _____" NPT.

The valve(s) shall be model _____ as manufactured by Crispin-Multiplex Manufacturing Co., Berwick, Pennsylvania.

Valve Parts List

ITEM	DESCRIPTION	MATERIAL	ASTM
1	BODY	CAST IRON	A126 CL.B
2	BOLT	STAINLESS STEEL	A193
3	DISC	STAINLESS STEEL	A240
4	SEAL	NITRILE	D2000
5	NUT	STAINLESS STEEL	A194
6	BOLT	STAINLESS STEEL	A193
7	SPRING	STAINLESS STEEL	A313
8	POPPET	DELIN	N/A
9	STRAINER	POLYPROPYLENE	N/A

Size Specifications

MODEL	INLET SIZE	OUTLET SIZE	A	B	WGHT.
FV20	2" NPT	2" NPT	3.50	6.25	3
FV30	3" NPT	3" NPT	5.50	9.25	8
FV40	4" NPT	4" NPT	6.75	11.25	15

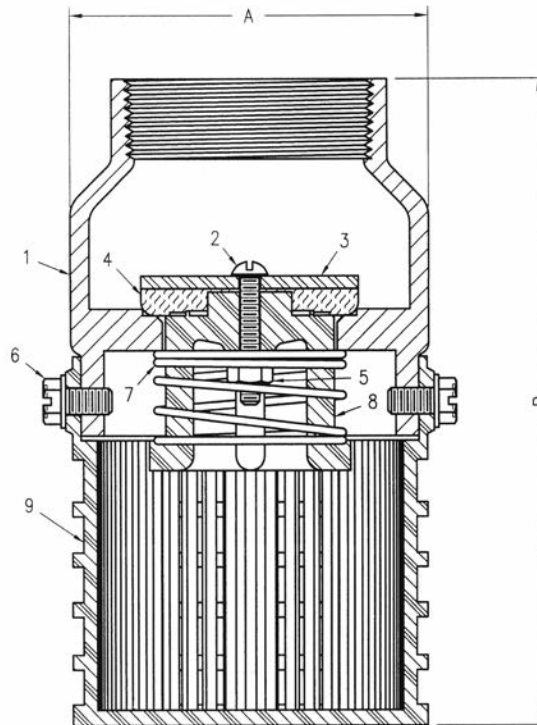

SUBMITTAL SHEET FOR FV SERIES