

# Submittal Sheet for Crispin FV Series



## 6"-16" Class 150 Foot Valve

Date: 2016

### Specifications

Foot Valve(s) shall be installed on the pump suction to prevent the pump column from draining upon pump shutdown.

The valve(s) shall be silent operating and normally closed. A center guided disc with a Buna-N seat shall provide a drip tight seal. Minimum flow area perpendicular to the direction of flow thru the valve shall be equal to the pipe area. The inlet shall be fitted with a stainless steel screen with a clear opening adequate to provide 3 to 4 times the area of the pipe.

3"-16" flanged: The valve(s) materials of construction shall include a ductile iron body, stainless steel disc, bushing and seat ring with a Buna-N seal; and stainless steel inlet screen. The flanged pipe connection shall be ANSI Class 150.

The valve(s) shall be model \_\_\_\_\_ as manufactured by Crispin-Multiplex Manufacturing Co., Berwick, Pennsylvania.

### Size Specifications

MODEL	INLET SIZE	OUTLET SIZE	A	B	WGHT.
FV61	6" 150# FLG	6" 150# FLG	11.50	16.00	100
FV81	8" 150# FLG	8" 150# FLG	14.00	20.75	166
FV101	10" 150# FLG	10" 150# FLG	16.50	25.75	276
FV121	12" 150# FLG	12" 150# FLG	19.50	26.75	396
FV141	14" 150# FLG	14" 150# FLG </td <td>21.50</td> <td>29.00</td> <td>465</td>	21.50	29.00	465
FV161	16" 150# FLG	16" 150# FLG	23.50	32.75	605

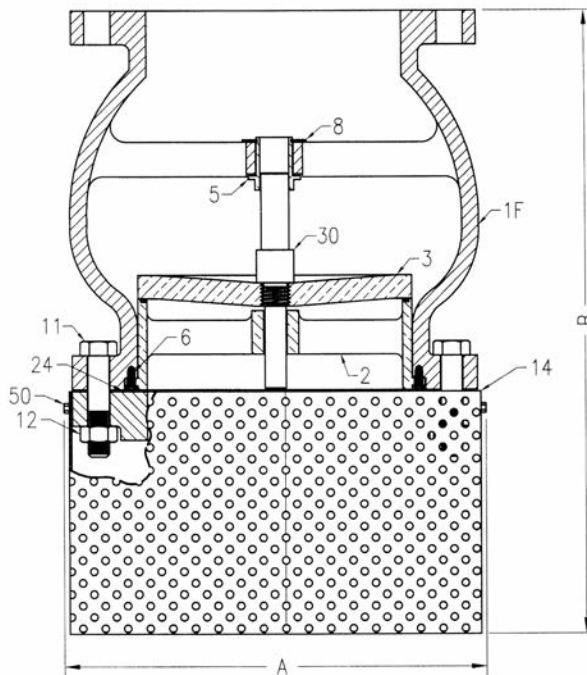

### Valve Parts List

ITEM	DESCRIPTION	MATERIAL	ASTM
1	BODY	DUCTILE IRON	A536
2	RESILIENT SEAT	STAINLESS STEEL/BUNA-N RUBBER	B62/D2000
3	DISC	STAINLESS STEEL	T316
5	BUSHING	STAINLESS STEEL	T316
6	SCREW	STAINLESS STEEL	A193
8	RETAINING RING	STAINLESS STEEL	A240
9	MOUNTING FLANGE	DUCTILE IRON	A536
11	BOLT	ZINC PLATED	A193
12	NUT	ZINC PLATED	A194
14	SCREEN	STAINLESS STEEL	A240
24	GASKET	ARMSTRONG N-8092	N/A
30	SHAFT	STAINLESS STEEL	T316
50	SCREEN RETAINING SCREW	STAINLESS STEEL	A193

SUBMITTAL SHEET FOR FV SERIES