

8 7 6 5 4 3 2 1

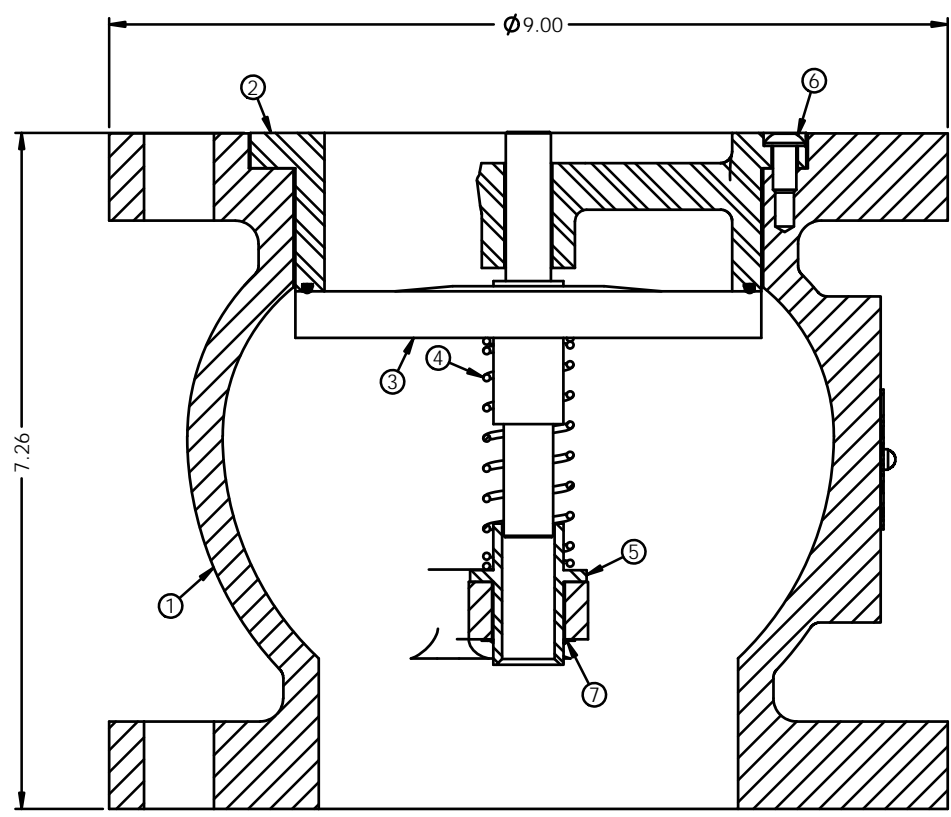

PARTS LIST				
ITEM NO.	PART NUMBER	DESCRIPTION	MATERIAL	QTY.
1	404-1F	BODY	DUCTILE IRON	1
2	404-2R	RESILIENT SEAT RING	BUNA-N & AL-BRZ	1
3	404-3	DISC	AL-BRONZE	1
4	404-4	SPRING	STAINLESS STEEL	1
5	404-5	BUSHING	AL-BRONZE	1
6	BHCS.25X.50	SCREW	STAINLESS STEEL	2
7	303-8	RETAINING RING	STAINLESS STEEL	1

FLANGE DATA	
FLANGE DIAMETER	9.00 in.
FLANGE THICKNESS	0.94 in.
BOLT CIRCLE DIAMETER	7.50 in.
NUMBER OF BOLT HOLES	8
BOLT HOLE DIAMETER	0.75 in.

- NOTES:**
- INLET SIZE: 4" CL. 150 FLANGED
OUTLET SIZE: 4" CL. 150 FLANGED
 - APPROXIMATE WEIGHT: 44 lbs
 - VALVE WILL BE COATED EXTERNALLY WITH PHENOLIC ALKYD PRIMER

REV.	DESCRIPTION	DATE	APPROVED
1	REDRAWN IN SOLIDWORKS	9-22-21	BJL

REVISIONS			
REV.	DESCRIPTION	DATE	APPROVED
1	REDRAWN IN SOLIDWORKS	9-22-21	BJL

NAME	DATE
DRAWN DJF	9-22-21
CHECKED	-
ENG APPR.	-
MFG APPR.	-
Q.A.	-

UNLESS OTHERWISE SPECIFIED: DIMENSIONS ARE IN INCHES XX DIMENSIONS ±.1 XXX DIMENSIONS ±.01 XXXX DIMENSIONS ±.005 DRILLED HOLES ±.01 ANGLES ±1° CONCENTRIC DIAMETERS SEE BELOW MACHINED 125 RMS MACHINED TO CAST 125 RMS MACHINED SURFACES 125 RMS BEFORE FINISH BREAK SHARP EDGES	MATERIAL: PER BOM	FILE LOCATION: \\S2\st1\Drawings\ASSEMBLY\GC\
PROPRIETARY AND CONFIDENTIAL THE INFORMATION CONTAINED IN THIS DRAWING IS THE SOLE PROPERTY OF CRISPIN VALVE. ANY REPRODUCTION IN PART OR AS A WHOLE WITHOUT THE WRITTEN PERMISSION OF CRISPIN VALVE IS PROHIBITED.	FINISH:	FILE NAME: GC41.R 8280329.r1

DO NOT SCALE DRAWING

CRISPIN VALVES
TITLE:
4" CL. 150 RESILIENT SEAT
GLOBE CHECK VALVE

SIZE	DWG. NO.	REV
B	GC41.R 8280329	1
SCALE: 0.75:1	WT: LB	SHEET 1 OF 1

8 7 6 5 4 3 2 1