

20" & 24" LUDLOW-RENSELAER RESILIENT WEDGE GATE VALVE

Options

- Bevel gear operator
- Spur gear operator
- Handwheel
- 2" AWWA operating nut

End Connections

- MJ x MJ
- FE x FE
- MJ x FE
- MJ x TAP



Installation of 24" Resilient Wedge Gate Valve

AWWA C515

The all ductile iron body, bonnet and seal plate resists corrosion and offers the same long service life as gray iron, but with less weight. It has increased strength, toughness and impact resistance. Each valve is pressure rated for 250 psi and tested for 500 psi performance which meets or exceeds AWWA C515.

Stem

The stem is made of high strength 304 stainless steel and is lead free.

Wedge Guides

Specially designed wedge guides reduce input torque required for operation. The guides also resist interference from debris in the waterway and protect the wedge from wear after years of service.

Full Diameter Waterway

The full diameter waterway is oversized providing a smooth unobstructed flow and also accommodates a full sized shell cutter.

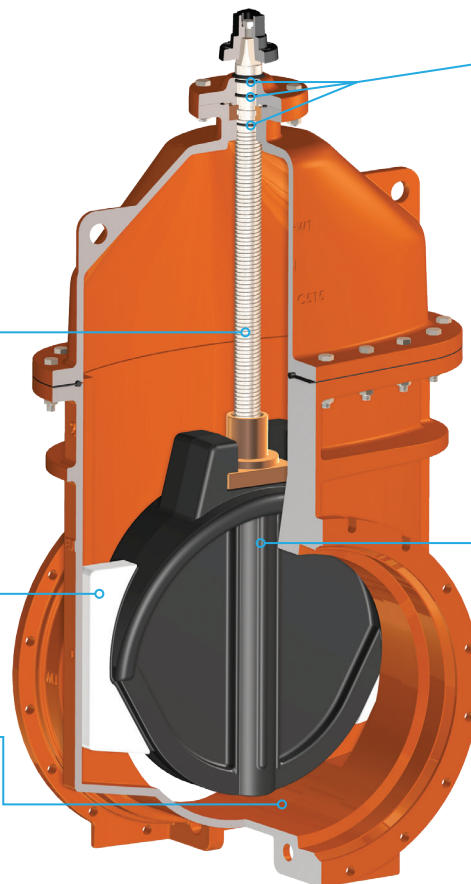

Triple O-Ring Seal

Three stem seal o-rings; two in the seal plate, which are replaceable with the valve in the full open position at rated working pressure, and one under the stem thrust collar.

Epoxy Coating

Fusion bonded epoxy coating provides outstanding corrosion resistance on all surfaces inside and out per AWWA C550 and is NSF 61 certified.

Ductile Wedge

The ductile iron wedge is rubber encapsulated which meets the requirements of ASTM D429. A ductile wedge is better able to handle waterline pressure and surges, while the permanent rubber coating ensures a watertight seal.

Bolts

All standard nuts and bolts are made of 304 stainless steel (316 stainless steel is optional).

**10 Year
Limited Warranty**