

## **“PX Series” Pressure Air Release Valve for Extreme Service**

PX Series REV. 0

### **INSTALLATION, OPERATION and MAINTENANCE MANUAL**

**Kiss Inline  
Backflushing  
Goodbye**

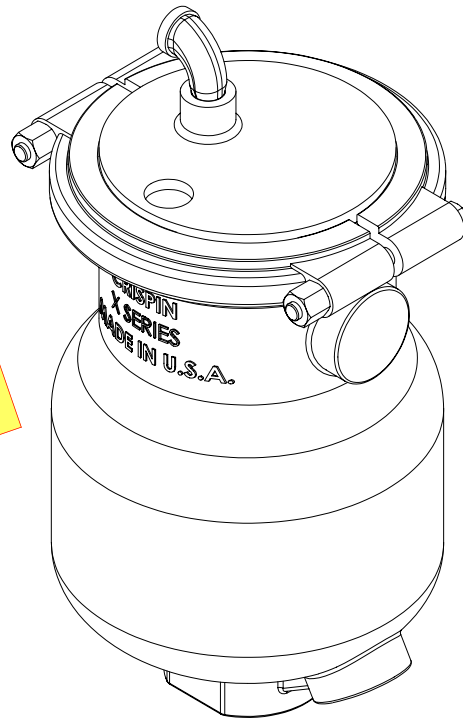

#### **Contents**

<b>Introduction—</b>	<b>Page 2</b>
<b>Installation—</b>	<b>Page 2</b>
<b>Operation—</b>	<b>Page 2</b>
<b>Disassembly—</b>	<b>Page 3</b>
<b>Reassembly—</b>	<b>Page 3</b>
<b>Maintenance—</b>	<b>Page 4</b>
<b>Service—</b>	<b>Page 4</b>

Also available in Air & Vacuum and Combination, the “X Series” valve features our exclusive head exchange system, with its head-fixed stainless steel valve internals. To clean, simply loosen the head assembly, which is sealed in place by a sanitary stainless clamp fitting. Pull out the original head, which weighs less than 10 lbs, and pop in a spare. Then clean the original internals at your leisure.

## Introduction

This manual will provide you with the information to properly install and maintain the Air & Vacuum valve to ensure a long service life. The "PX Series" Pressure Air Release Valve is ruggedly constructed with a 316 stainless steel body and trim to give years of trouble-free operation.

## Installation

The installation of the valve is important for its proper operation. The valve must be installed in the vertical position. Next, lower valve over the mating nipple or flange. If mounted on nipple, using Teflon tape, apply tape to the mating pipe nipple. Lightly thread the valve to the pipe nipple until tight. If using a flanged connection, align and apply the flange gasket on flange and lower the valve onto the mating flange. Then tighten flange bolts. If leakage occurs, check the connections and re-tape the threaded connection if necessary.

## Operation

The Crispin "PX Series" Pressure Air Release Valve is designed to release accumulating air while the line is in operation, and under pressure.

When the line is filled and under pressure. Liquid entering the valve raises the float and lever mechanism, carrying with it the pressure plunger in the main valve. When the liquid has raised the float to its limit, the pressure plunger also rests against its seat, which is the main valve. When this occurs, the valve is closed and no liquid can escape.

If accumulating air rises into the valve while the line is in operation and under pressure, it will displace the liquid at the top of the valve body, and the float will begin to drop as the liquid level drops. As this occurs, the pressure valve will open permitting escape of the accumulating air, after which the liquid level will rise and the valve will close.

The cycles will repeat automatically as each condition presents itself.

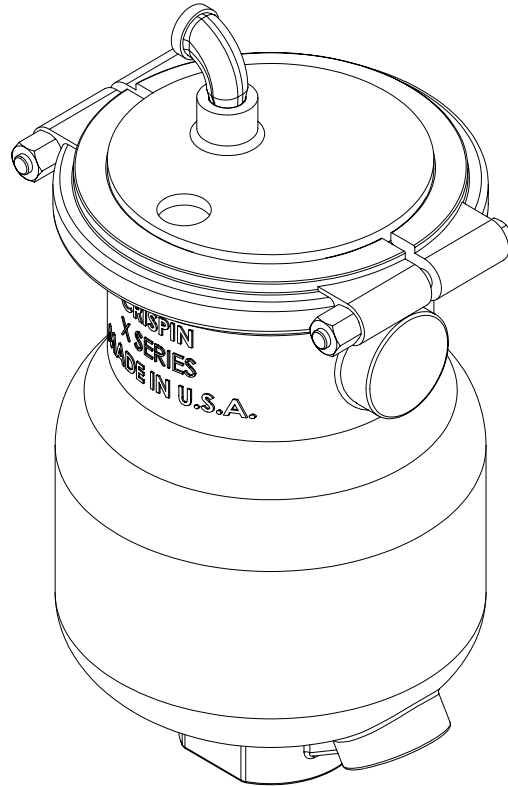

*Crispin's "PX Series" Valve*

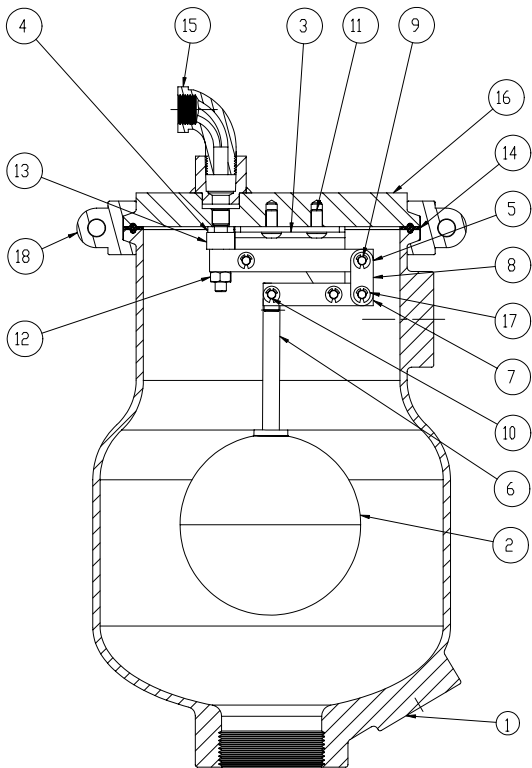

“PX Series” Valve

ITEM NO.	Description	MATERIAL	QTY.
1	2 " VALVE BODY	A351 CF8M, TYPE 316 S.S.	1
2	FLOAT	A240/A276 TYPE 316 S.S.	1
3	FULCRUM ASSEMBLY	A276/A240 TYPE 316 S.S.	1
4	SEAT	A276 TYPE 316 S.S.	1
5	VALVE LEVER	A276 TYPE 316 S.S.	1
6	FLOAT ROD	A276 TYPE 316 S.S.	1
7	BALL LEVER	A276 TYPE 316 S.S.	1
8	LINK	A240 TYPE 316 S.S.	2
9	BEARING PIN	A276 TYPE 316 S.S.	2
10	BEARING PIN	A276 TYPE 316 S.S.	1
11	SBHCSCREW 0.25-20x0.5-HX-N	TYPE 316 S.S.	2
12	HNUT 0.2500-28-D-N	TYPE 316 S.S.	1
13	PLUNGER	BUNA-N RUBBER / 316 SS	1
14	GASKET	Buna-N	1
15	3/8 NPT ELBOW	316 S.S.	1
16	COVER ASSEMBLY	A276/A240 ER 308/308L 316 SS	1
17	3/16 RETAINING RING	TYPE 316 S.S.	5
18	TC FERRULE CLAMP	TPYE 316 S.S.	1

## Disassembly

1. Remove Flange Clamp (18) by turning nuts counter clockwise. Remove Flange (16) From Valve Body (1) by lifting straight up.
2. Remove Screws (11) from Top Flange (16). Inspect the valve linkage assembly for bent parts.
3. Inspect the valve Plunger (13) for wear. If worn, replace and reset.
4. Inspect Flange Gasket (14). Replace if needed.

## Reassembly

1. Install the valve internals to the top flange (16) using Screws (11). Be sure to inspect, & if worn replace the Seat if worn (4).
2. Turn top flange (1) upside down & move linkage into the closed position to be sure the linkage is not toggled (toggled-over extended).
3. Apply talcum powder to the plunger (13). Work the linkage back and forth so that the contact between the plunger (13) and seat (4) is visible. If proper contact is not evident, adjust the valve plunger (13).
4. Apply gasket (14) to the valve body (1).
5. Gently lower the top flange (16) on to the valve body (1). Once aligned, use flange clamp (18) around the two parts, then tighten nuts.

*Note: During routine maintenance, it is advised to replace the valve seat.*

**NOTE:** The valve does not have to be removed from the pipeline for disassembly. All work on the valve should be performed by a skilled mechanic using the proper tools.

## **Maintenance**

Although Crispin "PX Series" Pressure Air Release valves do not require back flushing, it is recommended to have a spare valve head assembly on hand to "swap out" in the field. The head assembly removed from the valve can then be cleaned and put into stock, to be used the next time around. Depending on each specific system, Crispin recommends to swap head assemblies every 6-12 months.

## **Service**

Parts and service are available from your local representative or distributor. Make note of the Valve size, operating pressure and model number located on the valve tag.



Crispin Valve      600 Fowler Avenue      Berwick, PA 18603  
P: (800) AIR-VALV or (570) 752-4524      F: (570) 752-4962