



Submittal Sheet for Crispin SL Series

2"-4" Pressure Sewer Valve (stan.) (1 of 2)

Manufactured in compliance with ANSI/AWWA C512

Date: 2016

Specifications

The Pressure Sewer Air Release Valve(s) shall be installed at high points in the line, or at points selected by the engineer, to vent the accumulation of air and other gases with the line under pressure.

The valve(s) shall be of the long body design and shall have a _____" orifice with an adjustable Buna-N rubber valve and a sealing face of PVC. The valve(s) shall operate at _____ PSIG, and be capable of passing _____ SCFM of air.

They shall also be _____" NPT screwed or ANSI Class (125, 250) flanged connection. They shall have a cast iron body, top and flange, where required, and a stainless steel trim.

The valve(s) shall be Crispin Model _____ Pressure Sewer Valve(s) as manufactured by Crispin-Multiplex Manufacturing Co., Berwick, PA.

Option: The valve(s) shall be supplied with back flushing attachments so that the interior body can be flushed periodically for proper operation.

Option: Where pressures are greater than 300 PSIG, the valve(s) shall be ANSI Class _____ flanged inlet connection, and shall have a (steel, stainless steel, or ductile iron) body, top and inlet flange.

Standard operating pressure for Crispin Air Valves is 20 to 150 PSIG. Please check one of the following if your operating needs differ:

- _____ 2 to 40 PSIG
- _____ 151 to 300 PSIG

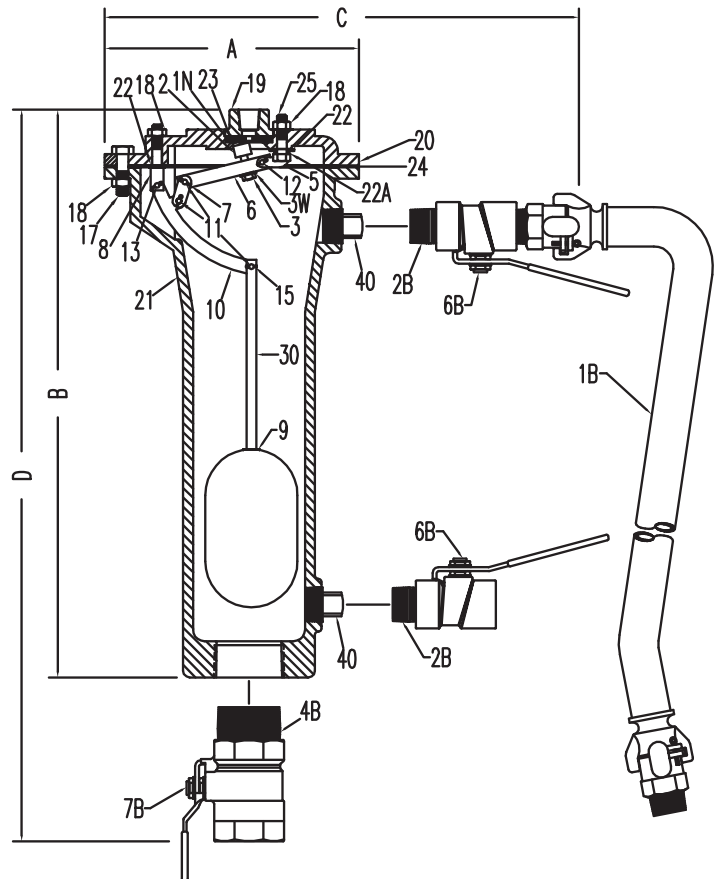

Orifice Options

DIAMETER	MAX. PRESSURE	DISCHARGE RATE
1/4	150 PSIG	105 SCFM
1/8	300 PSIG	50.26 SCFM

All Crispin valves are hydrostatically tested at 150% of their maximum working pressure