

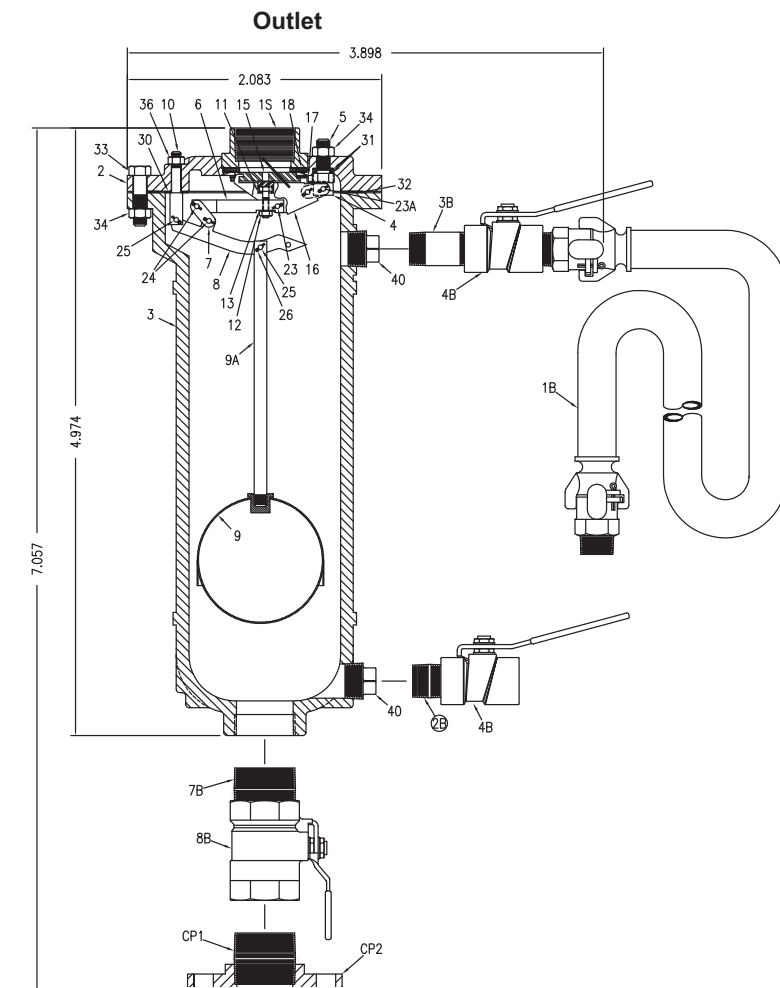

# US SERIES



Note: Inlet Gate Valve is included when backflushing attachments are provided.

## Dimensions and Weights

Model	Inlet x Outlet	Height	Height w/Backflush	Width	Width w/Backflush	Weight	Weight. w/Backflush	Trim
USL20	2" x 1"	21 1/2"	25 3/4"	9 11/16"	11 1/4"	49lbs	60lbs	SS
US20	2" x 2"	25 3/4"	29 1/2"	10 1/16"	13 1/2"	93lbs	105lbs	SS
US21	2" x 2"	29 1/4"	36 1/4"	10 1/16"	13 1/2"	106lbs	136lbs	SS
US30	3" x 3"	29"	34 3/8"	11"	15"	127lbs	144lbs	SS
US31	3" x 3"	29"	37 3/8"	11"	15"	137lbs	190lbs	SS
US40	4" x 4"	31"	37"	12 1/2"	16 1/2"	135lbs	159lbs	SS
US41	4" x 4"	31"	40 1/4"	12 1/2"	16 1/2"	149lbs	226lbs	SS
US61	6" x 6"	26 1/2"	37"	14 1/2"	26 1/2"	210lbs	360lbs	IBBT