

Submittal Sheet for Crispin US Series

2" (2" I X 1" O) Universal Sewer (stan.)

Manufactured in compliance with ANSI/AWWA C512

Date: 2016

Specifications

The valve(s) shall be installed at the high points in the system, or at points selected by the engineer. This will permit discharging the surge of air from an empty line when filling, and relieve the vacuum when draining the system. The valve(s) shall also release an accumulation accomplished in a single valve body.

The valve shall operate through a compound lever system that will seal both the pressure orifice and the Air and Vacuum orifice simultaneously.

This lever system shall permit a _____" orifice to release an accumulation of air from the valve body at a capacity of _____ SCFM of air at a pressure of _____ PSIG.

The valve body shall be cast iron. The internal linkage and float shall be stainless steel. The valve(s) shall be Crispin Model _____ Universal Sewer Air Valve, as manufactured by Crispin-Multiplex Manufacturing Co., Berwick, PA. The valve(s) shall be _____" NPT screwed as ANSI Class (125, 250) flanged inlet connection.

Valves which operate with the Air and Vacuum Valve disc held in a cradle with slots through which the air must flow will not be acceptable.

Option: A protectop shall be supplied to prevent dirt and debris from entering the outlet of the valve.

Option: The valves shall be supplied with backflushing attachments so that the interior body can be flushed periodically for proper operation.

Standard operating pressure for Crispin Air Valves is 20 to 150 PSIG. Please check one of the following if your operating needs differ: _____ 2 to 40 PSIG _____ 151 to 300 PSIG

Orifice Options

DIAMETER	MAX. PRESSURE	FLOW RATE
3/16	150 PSIG	54.6 SCFM
3/32	300 PSIG	26.4 SCFM

Size Specifications

MODEL	INLET SIZE	OUTLET SIZE	A	B	C	D	WHT.
USL20	2" NPT	1" NPT	9.75	21.50			50
USL20B	2" NPT	1" NPT			12.25	27.00	62

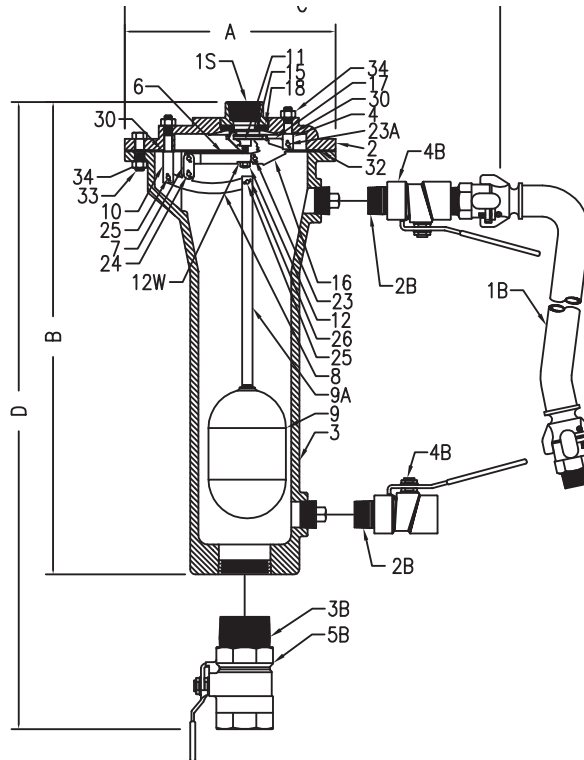

Parts List

ITEM	QTY.	DESCRIPTION	MATERIAL	ASTM
1S	1	TOP	CAST IRON	A126 CL.B
2	1	FLANGE	CAST IRON	A126 CL.B
3	1	BODY	CAST IRON	A126 CL.B
4	1	AIR & VACUUM FULCRUM	STAINLESS STEEL	A582
6	1	VALVE LEVER	STAINLESS STEEL	A582
7	2	LINK	STAINLESS STEEL	A240
8	1	BALL LEVER	STAINLESS STEEL	A240
9	1	FLOAT	STAINLESS STEEL	A240
9A	1	FLOAT ROD	STAINLESS STEEL	A582
10	1	BALL FULCRUM	STAINLESS STEEL	A582
11	1	PLUNGER	S/S & BUNA-N RUBBER	D2000
12	1	PLUNGER NUT	STAINLESS STEEL	A194
12W	1	LOCK WASHER	STAINLESS STEEL	A240
15	1	PRESSURE SEAT	STAINLESS STEEL	A582
16	1	PRESSURE FULCRUM	STAINLESS STEEL	A240
17	1	SEAT CAGE	STAINLESS STEEL	A240
18	1	SEAT	BUNA-N RUBBER	D2000
23	1	BEARING PIN	STAINLESS STEEL	A582
23A	1	BEARING PIN	STAINLESS STEEL	A582
24	2	BEARING PIN	STAINLESS STEEL	A582
25	2	BEARING PIN	STAINLESS STEEL	A582
26	6	COTTER PIN	STAINLESS STEEL	A313
30	2	FULCRUM WASHER	FIBER	N/A
32	1	FLANGE GASKET	ARMSTRONG N-8092	N/A
33	7	BOLT	STEEL	A307
34	9	NUT	STEEL	A563
*40	2	FLUSH PLUG	CAST IRON	A126 CL.B

OPTIONAL BACK FLUSH COMPONENTS

*1B	1	HOSE ASSEMBLY	S/S, CAD PLT, RUBBER	N/A
*2B	2	NIPPLE	STEEL	A53
*3B	1	NIPPLE	STEEL	A53
*4B	2	BALL VALVE	BRASS	B505
*5B	1	BALL VALVE	BRASS	B505



SUBMITTAL SHEET FOR US SERIES