

PARTS LIST				
ITEM NO.	PART NUMBER	DESCRIPTION	MATERIAL	QTY.
1	36-U3X-2	COVER FLANGE	316 STAINLESS STEEL	1
2	28-3XF	BODY	A351 GR. CF8M	1
3	AS568-272	FLANGE O-RING	BUNA-N RUBBER	1
4	36-A3X-5	AIR / VAC SEAT	BUNA-N RUBBER	1
5	28-16X	FLOAT GUIDE STAND	A351 GR. CF8M	1
6	HCSS.38X.88	SEAT RETAINER BOLT	316 STAINLESS STEEL	6
7	28-15X	VALVE DISC	316 STAINLESS STEEL	1
8	13-4N	VALVE PLUNGER	BUNA-N & 316 S/S	1
9	FJHN.25-28	PLUNGER NUT	316 STAINLESS STEEL	1
10	36-A6X-16	VALVE GUIDE PLATE	316 STAINLESS STEEL	1
11	36-A6X-18	SHOULDER BOLT	316 STAINLESS STEEL	3
12	36-A3X-9	FLOAT	316 STAINLESS STEEL	1
13	28-11X	CLAMP HALF	A351 GR. CF8M	2
14	3-11FH	CLAMP BOLT	316 STAINLESS STEEL	2
15	LW.5	LW-.5	316 STAINLESS STEEL	2
16	3-12	CLAMP NUT	316 STAINLESS STEEL	2
17	PLG-1	DRAIN PLUG	316 STAINLESS STEEL	2

FLANGE DATA	
FLANGE DIAMETER	7.50 in.
FLANGE THICKNESS	0.94 in.
BOLT CIRCLE DIAMETER	6.00 in.
NUMBER OF BOLT HOLES	4
DIAMETER OF BOLT HOLES	0.75 in.
RAISED FACE DIAMETER	5.00 in.
RAISED FACE HEIGHT	0.06 in.

ORIFICE DATA	
DIAMETER	WORKING PRESSURE
5/32	20-200 PSIG

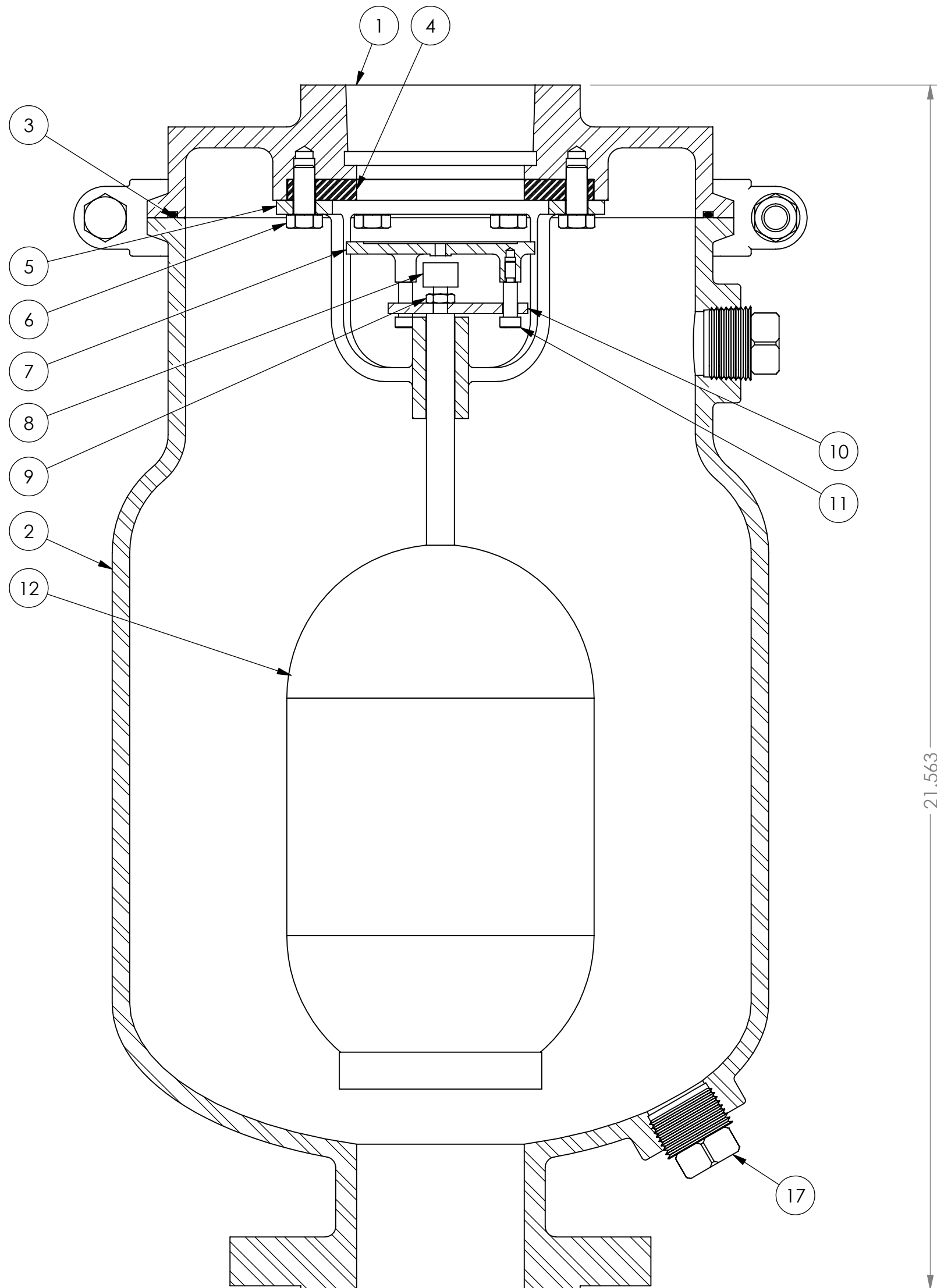

SECTION A-A

- NOTES:
1. INLET SIZE: 3" CLASS 150 RAISED FACE FLANGE
OUTLET SIZE: 3" NPT
 2. APPROXIMATE WEIGHT: 102 lbs.
 3. VALVE IS DESIGNED TO WITHSTAND PRESSURE SURGES UP TO 285 PSIG

CRISPIN VALVES

3" CLASS 150
UNIVERSAL PRESSURE
AIR RELEASE VALVE

DO NOT SCALE DRAWING
DIMENSIONS ARE IN INCHES [mm]

REDRAWN: DJF 8-1-19
CHECKED:
DRAWN: C. GEARY 07/20/10

SIZE C DWG. NO. UX31 REV 0

REV	DATE	BY	APPD	REVISION