

PARTS LIST				
ITEM NO.	PART NUMBER	DESCRIPTION	MATERIAL	QTY.
1	36-U4X-2	COVER FLANGE	A351 GR. CF8M	1
2	28-3X-4F	BODY	A351 GR. CF8M	1
3	AS568A-272	FLANGE O-RING	BUNA-N RUBBER	1
4	36-A4X-5	SEAT	BUNA-N RUBBER	1
5	29-16X	FLOAT GUIDE STAND	A351 GR. CF8M	1
6	29-15X	VALVE	A351 GR. CF8M	1
7	28-4N	VALVE PLUNGER	BUNA-N & 316 S/S	1
8	FJHN.25-28	PLUNGER NUT	316 STAINLESS STEEL	1
9	36-A6X-16	VALVE GUIDE PLATE	316 STAINLESS STEEL	1
10	36-A6X-18	SHOULDER BOLT	316 STAINLESS STEEL	3
11	36-A4X-9	FLOAT	316 STAINLESS STEEL	1
12	HHCS.375X.88	SEAT RETAINER BOLT	316 STAINLESS STEEL	6
13	28-11X	CLAMP HALF	A351 GR. CF8M	2
14	HHCS.5X3.5	CLAMP BOLT	316 STAINLESS STEEL	2
15	LW.5	LOCK WASHER	316 STAINLESS STEEL	2
16	FHN.5-13	CLAMP NUT	316 STAINLESS STEEL	2
17	36-33	PLUG	316 STAINLESS STEEL	2

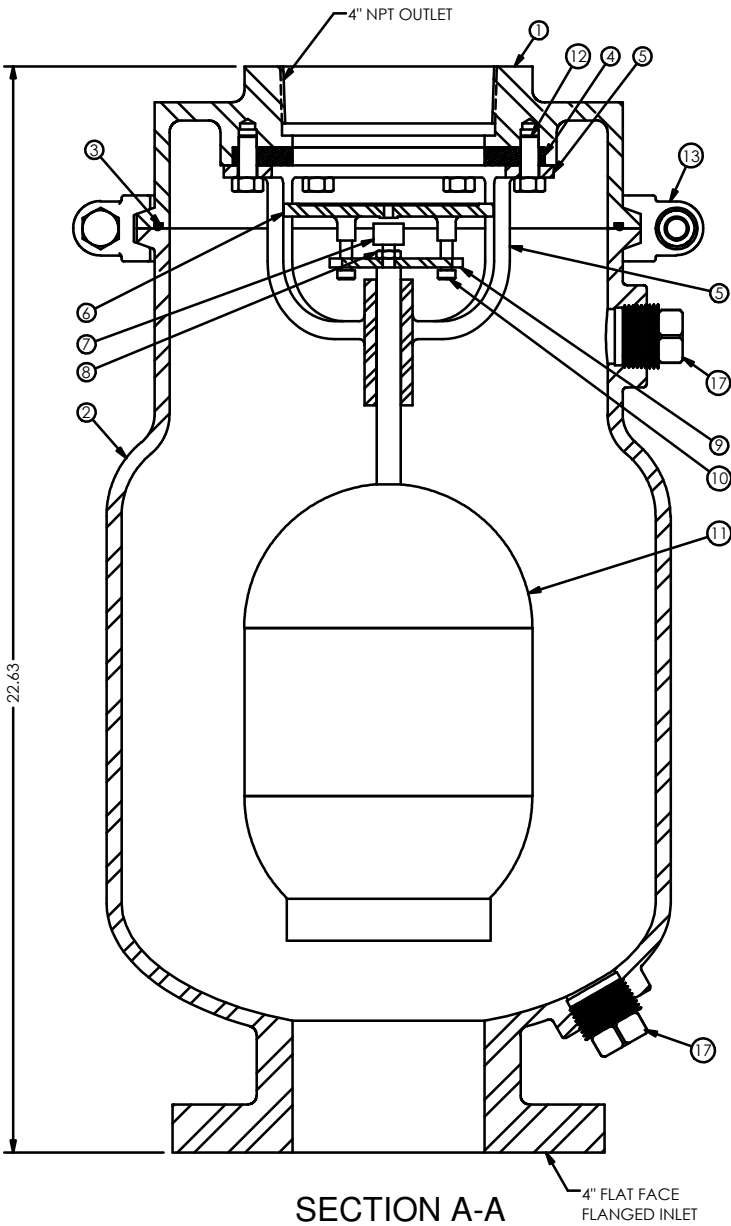

ORIFICE DATA	
DIAMETER	WORKING PRESSURE
3/16	20-150 PSIG

INLET FLANGE DATA	
FLANGE DIAMETER	9.00 in.
FLANGE THICKNESS	0.94 in.
BOLT CIRCLE DIAMETER	7.50 in.
NUMBER OF BOLT HOLES	8
BOLT HOLE DIAMETER	0.75 in.

- NOTES:
1. INLET SIZE: 4" CLASS 150 FLANGED OUTLET SIZE: 4" NPT
 2. APPROXIMATE WEIGHT: 127 lbs.

CRISPIN VALVES

4" CLASS 150
UNIVERSAL PRESSURE
AIR RELEASE VALVE

SIZE	DWG. NO.	REV
C	UX41	2

REV	DATE	BY	APPD	REVISION	DRAWN	CHECKED	DRAWN/DWF	12-8-11
2	10/14/12	CTG		NOTE 1 ... HOODED OUTLET				
1	8/2/12	CTG		REMOVED ITEMS 3, 6, 8, 19, 20, 1E & 1C REPLACED ITEM 7 WITH 29-16X ADDED ITEM 26	REDRAWN:			
					CHECKED:			