

PARTS LIST				
KEY	PART No.	DESCRIPTION	MATERIAL	QTY
1	36-U6X-2	COVER FLANGE	A351 GR. CF8M	1
2	28-3X-6FF	VALVE BODY	A351 GR. CF8M	1
3	AS568A-272	COVER O-RING	BUNA-N RUBBER	1
4	36-A6X-3	SEAT RETAINER	316 STAINLESS STEEL	1
5	36-A6X-5	SEAT	BUNA-N RUBBER	1
6	36-A6X-6	VALVE DISC	316 STAINLESS STEEL	1
7	13-4N	PLUNGER	BUNA-N & 316 S/S	1
8	FJHN.25-28	PLUNGER NUT	316 STAINLESS STEEL	1
9	36-A6X-7	ROD GUIDE STAND	316 STAINLESS STEEL	1
10	36-A6X-8	ROD GUIDE	NYLATRON	1
11	JFHN1.125-7	GUIDE NUT	316 STAINLESS STEEL	1
12	36-A6X-9	FLOAT	316 STAINLESS STEEL	1
13	36-A6X-16	VALVE GUIDE PLATE	316 STAINLESS STEEL	1
14	36-A6X-18	SHOULDER SCREW	316 STAINLESS STEEL	3
15	36-A6X-13	STAND OFF	316 STAINLESS STEEL	4
16	HHCS.375X.88	SEAT RETAINER BOLT	316 STAINLESS STEEL	8
17	28-11X	CLAMP HALF	A351 GR. CF8M	2
18	HHCS.5X3.5	CLAMP BOLT	316 STAINLESS STEEL	2
19	LW.5	LOCK WASHER	316 STAINLESS STEEL	2
20	FHN.5-13	CLAMP NUT	316 STAINLESS STEEL	2
21	36-33	PLUG	316 STAINLESS STEEL	2

FLANGE DATA	
FLANGE DIAMETER	11.00 in.
FLANGE THICKNESS	1.00 in.
BOLT CIRCLE DIAMETER	9.50 in.
NUMBER OF BOLT HOLES	8
BOLT HOLE DIAMETER	0.88 in.

ORIFICE DATA	
DIAMETER	5/32
WORKING PRESSURE	20-200 PSIG

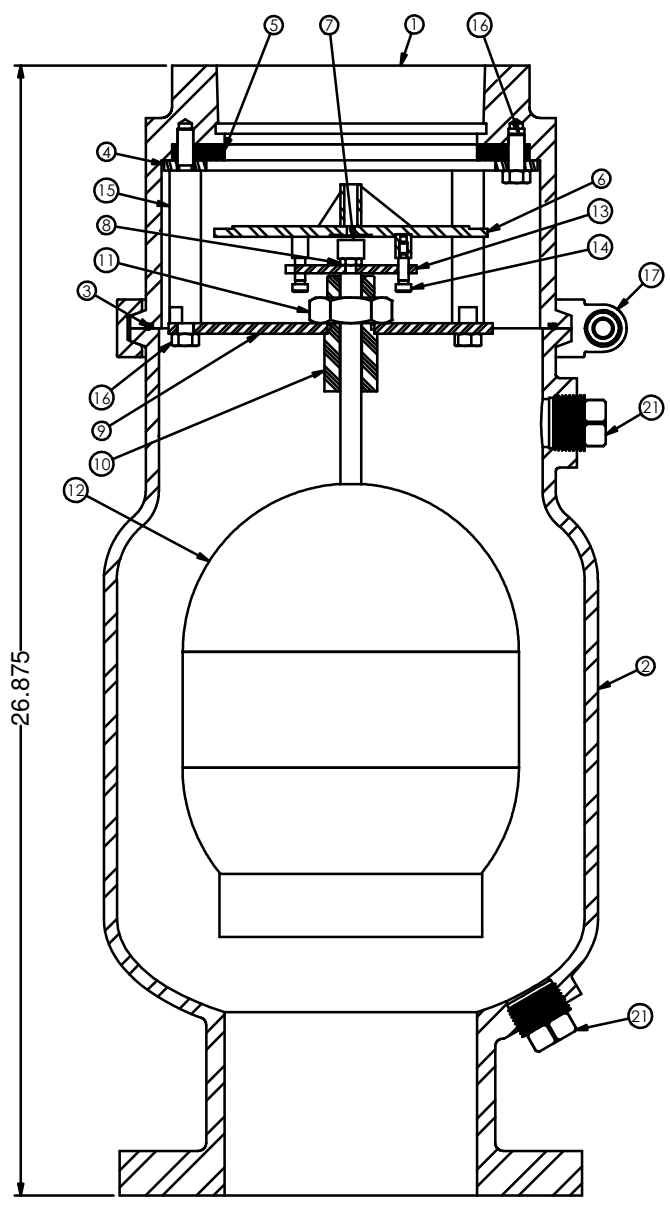

- NOTES:
1. INLET SIZE: 6" CLASS 150 FLAT FACED FLANGE
OUTLET SIZE: 6" NPT
 2. APPROXIMATE WEIGHT: 149 lbs.
 3. FLANGE RATING: 250 psig

CRISPIN VALVES
6" CLASS 150
UNIVERSAL PRESSURE
AIR RELEASE VALVE

SECTION C-C

1	10-3-16	DJF		CHG'D STAND OFF & VALVE ASSEMBLY	REDRAWN: DJF	1-4-16	SIZE	DWG. NO.	UX61	REV	1
REV	DATE	BY	APPD	REVISION	CHECKED:		C				
					DRAWN: DJF	9-1-16					