

8 7 6 5 4 3 2 1

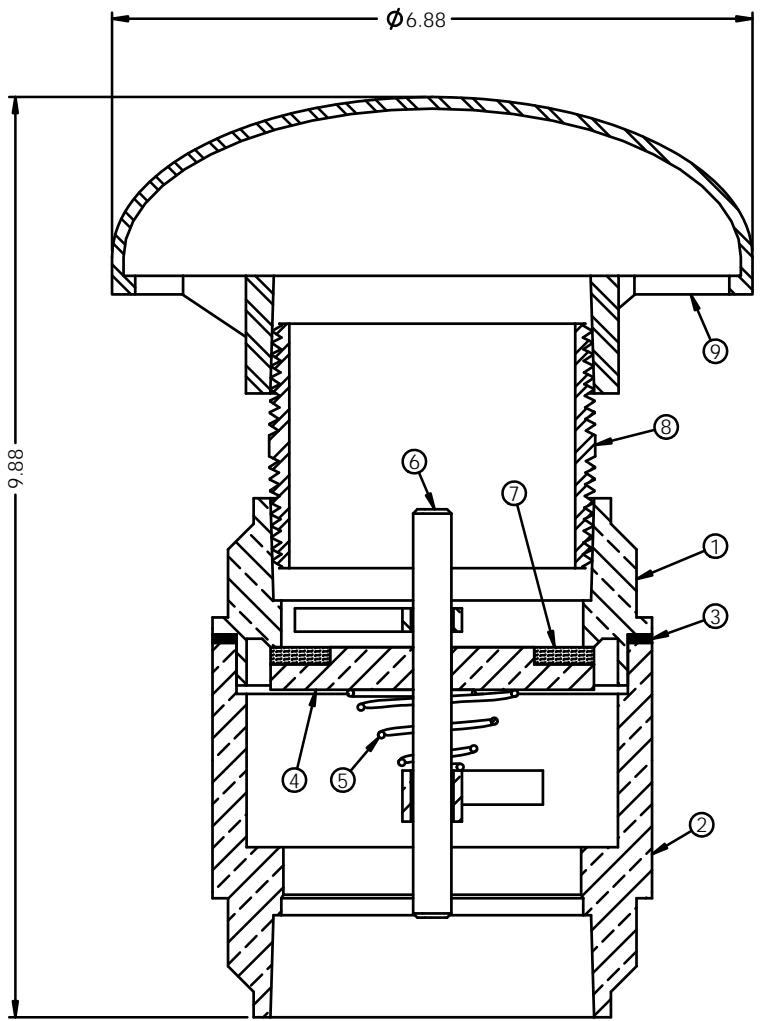

SECTION B-B

| ITEM NO. | PART NUMBER | DESCRIPTION | Material | QTY. |
|----------|-------------|---------------------|------------------|------|
| 1 | VR30 | CAP | AL-BRONZE | 1 |
| 2 | | BODY | AL-BRONZE | 1 |
| 3 | | GASKET | PTFE | 1 |
| 4 | | DISC | AL-BRONZE | 1 |
| 5 | | SPRING | STAINLESS STEEL | 1 |
| 6 | | STEM | AL-BRONZE | 1 |
| 7 | | RESILIENT SEAT RING | BUNA-N RUBBER | 1 |
| 8 | NPL 3XC | NIPPLE | STEEL | 1 |
| 9 | MVC-3 | VENT CAP | GALVANIZED STEEL | 1 |

- NOTES:
1. INLET SIZE: 3" NPT
OUTLET SIZE: 3" HOODED
 2. APPROXIMATE WEIGHT: 15 lbs
 3. VALVE WILL BE COATED EXTERNALLY WITH PHENOLIC ALKYD PRIMER

| | | | | |
|-----------------------------|-----------|-----------------|--------------------|-----------------------------|
| UNLESS OTHERWISE SPECIFIED: | | NAME | DATE | CRISPIN VALVES |
| DIMENSIONS ARE IN INCHES | | DRAWN | DJF | |
| XX DIMENSIONS | + .1 | CHECKED | - | TITLE: |
| X XX DIMENSIONS | + .01 | ENG APPR. | - | 3" NPT, VACUUM RELIEF VALVE |
| XXX DIMENSIONS | + .005 | MFG APPR. | - | SIZE DWG. NO. |
| DRILLED HOLES | + .01 | O.A. | - | B VR30 |
| ANGLES | + .1° | FILE LOCATION: | REV | |
| CONCENTRIC DIAMETERS | SEE BELOW | FILE NAME: VR30 | 0 | |
| MACHINED | .005 TIR | | SCALE: 0.75 WT: LB | |
| MACHINED TO CAST | .02 TIR | | SHEET 1 OF 1 | |
| MACHINED SURFACES | 125 RMS | | | |
| BEFORE FINISH | | | | |
| BREAK SHARP EDGES | | | | |
| MATERIAL: | | | | |
| FINISH: | | | | |

PROPRIETARY AND CONFIDENTIAL
 THE INFORMATION CONTAINED IN THIS
 DRAWING IS THE SOLE PROPERTY OF
 CRISPIN VALVE. ANY REPRODUCTION IN
 PART OR AS A WHOLE WITHOUT THE
 WRITTEN PERMISSION OF CRISPIN VALVE IS
 PROHIBITED.

DO NOT SCALE DRAWING

8 7 6 5 4 3 2 1